

目 录 索 引 Contents

减速机的工作系数和安装注意事项	Service factor & Installation notice	2
蜗轮减速机	Worm geared motors and worm gear units	3
电机直联尺寸	Predisposition	5
啮合参数表	Mesh data	6
NMRV性能参数	NMRV Performance	7
NRV性能参数	NRV Performance	17
NMRV/NRV型号标记	NMRV/NRV Model & marker	20
NMRV外形尺寸	NMRV Dimensions	24
NRV外形尺寸	NRV Dimensions	33
NMRV英制系列	NMRV Inch series	35
PC-NMRV型号标记	PC-NMRV Model & marker	39
PC-NMRV组合方式	PC-NMRV Combinations	40
PC-NMRV外形尺寸	PC-NMRV Dimensions	42
NMRV-NMRV型号标记	NMRV-NMRV Model & marker	45
NMRV-NMRV参数表	NMRV-NMRV Parameter table	47
NMRV-NMRV外形尺寸	NMRV-NMRV Dimensions	48
NRV-NMRV外形尺寸	NRV-NMRV Dimensions	51
PAM外形尺寸	PAM Dimensions	52
UDL系列行星锥盘无级变速器	UDL Series planetary cone & disk step-less speed variator	53
UDL型号标记	UDL Model & marker	54
UDL外形尺寸	UDL Dimensions	56

参数符号对应表 Parameter & symbol contrast table

P = 功率 Power (kW)	1 = 输入轴 Input shaft
M = 扭力 Torque (Nm)	2 = 输出轴 Output shaft
n = 速度 Speed (rpm)	r = 径向 Radial
i = 减速比 Ratio	a = 轴向 Axial
F = 负荷 Load (N)	s = 静态 Statical
m = 重量 Weight (kg)	d = 动态 Dynamic
η = 效率 Efficiency	max = 最大值
γ = 前置角 Helix angle	min = 最小值
f. s. = 工作系数 Service factor	



参数减速机的工作系数 Service factor

减速机的工作系数(f. s.)主要取决于减速机的运作条件, 其决定因素为

1. 减速机的负荷形式: A—B—C
2. 工作时间: 小时/天(Δ)
3. 开机频率: 次/小时(*)

减速机的三种符合形式:

1. A: 均等负荷 $fa \leq 0.3$
2. B: 中等负荷 $fa \leq 3$
3. C: 重量负荷 $fa \leq 10$

$$Fa = J_e / J_m$$

— $J_e(\text{kgm}^2)$: 在电机轴上发生衰降的惯性矩

— $J_m(\text{kgm}^2)$: 电机惯性矩

注意: $fa > 10$ 时请与技术服务部联系

The service factor(f. s.)depends on the operating conditions the gearbox is subjected to. Following parameters need to be take to select the right service factor.

- type of load of the operating machine A - B - C
- length of daily operating time: hours/day(Δ)
- start-up frequency: starts/hour (*)

TYPE OF LOAD: A-uniform, $fa \leq 0.3$

B-moderate shocks, $fa \leq 3$

C-heavy shocks, $fa \leq 10$

$$fa = J_{ex} / J_m$$

— $J_{ex}(\text{kgm}^2)$ moment of the external inertia reduced at the drive shaft

— $J_m(\text{kgm}^2)$ moment of inertia of motor

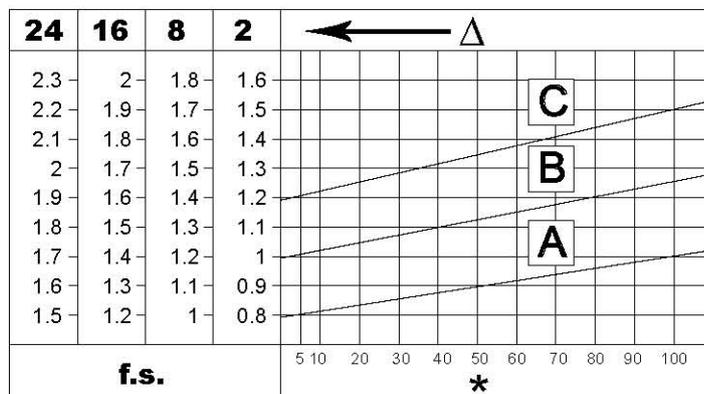

安装注意事项 To install the reduction unit it is necessary to note the following recommendations

- 减速机要平稳安装, 避免震动。
- 与机器装配前, 请检查减速机的输出轴的旋转方向是否正确。
- 在减速机放置时间长达4—6个月情况下, 应检查密封圈是否因不浸润在润滑油中而与轴发生粘连或失去弹性, 必要时更换密封圈。
- 安装空心轴时, 应采用专用力矩扳手。若无该条件时, 用户可自行选用专用工具, 但应确保轴向不受力, 减速机可自由移动。
- 减速机应避免受日光直射和雨淋。
- 确保通风条件良好。
- 工作环境温度低于-5° 或高与40° 时, 请咨询技术服务部。
- 皮带盘, 齿轮, 联轴器, 轴等通过特殊螺纹孔装于实心轴或空心轴, 该螺纹孔可防止运作时损伤轴承和机件表面, 应对机件表面作适当润滑, 以防锈蚀和卡塞。
- 橡胶件和透气孔不可上油漆。
- 安装完毕后, 取出油孔上的封口栓塞, 换上透气栓塞。
- 检查油位高度。
- 如果减速机不连接电机时, 请参考以下注意事项以确保正确连接: 安装于B5, B14
- 检查轴与电机法兰之公差是否符合基本标准。
- 清洗轴、中心孔和法兰表面的污迹及油漆。
- 安装时避免减速机受力。
- 检查马达键槽的位置和偏差。
- 用润滑油涂抹轴的表面, 以防生锈或卡塞。
- 开机时应分级起动, 不能满负荷起动。
- 装配在电机下方的机件及材料易于受损, 应采取适当的防范措施。

- The mounting on the machine must be stable to avoid any vibration.
- Check the correct direction of rotation of the reduction unit output shaft before fitting the unit to the machine.
- In the case of particularly lengthy of periods of storage (4-6 months) if the oil seal is not immersed in the lubricant inside recommended to change it since the rubber could stick to the shaft or even has lost the elasticity it needs to function properly
- For a shaft mounting, for reduction units with a hollow output shafts, use the torque arms motionclinic can supply. If it is n make sure that the constraint is axially free and with such as play as to ensure free movement to the reduction unit.
- Whenever possible, protect the reduction unit against solar radiation and bad weather.
- Ensure the motor cools correctly by assuring good passage of air from the fan side.
- In the case of ambient temperatures $< -5^{\circ} \text{C}$ and $> +40^{\circ} \text{C}$ contact motionclinic.
- The various parts (pulleys, gear wheels, couplings, shafts, etc.) must be mounted on the solid or hollow shafts using special holes or other systems that anyhow ensure correct operation without risking damage to the bearings or external parts of the uni
- Painting must definitely not go over rubber parts and the holes on the breather plugs, if there are any.
- Taking out the seal embolism of the oilhole.
- Check the height of the oil level.
- Supposing the gear unit have not coupled with the motor, please pay attention to the following items to make sure rightly connection. Mounting to B5, B14
- Check whether the tolerance between the shaft and motor flange fit for the essential standard.
- Washing the dirt and the paint on the surfaces of the shaft, center bore and the flange.
- Mounting avoid the gear unit incur strength.
- Check the position and the decination of the motor keyslot.
- Lubricate the surfaces in contact to avoid seizure or oxidation.
- Starting must take place gradually, without immediately applying the maximum load.
- When there are parts objects or materials under the motor drive that can be damaged by even limited spillage of oil, special should be fitted.

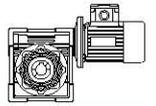

蜗 轮 减 速 机

Worm geared motors and worm gear units

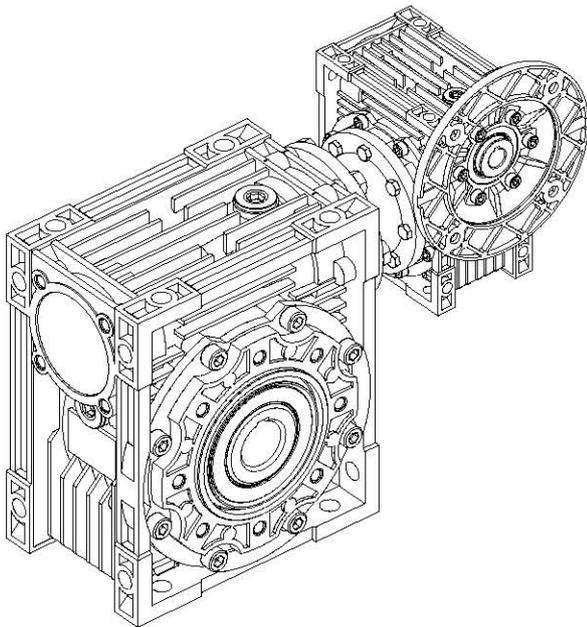

NMRV+NMRV

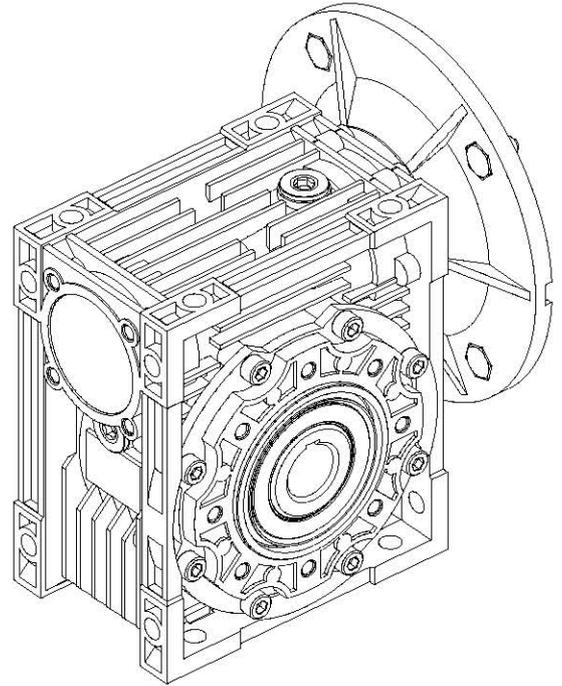

NMRV

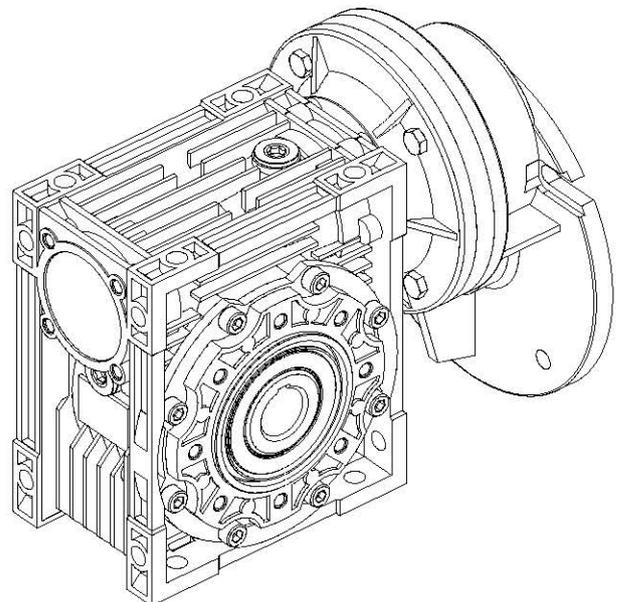

PC+NMRV

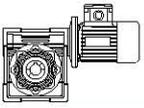

蜗轮减速机型号 Versions

	NMRV 025-130	NMRV 025-130 F	
	NRV 025-130	NRV 025-130 F	
	NMRV-NMRV 025-130	NMRV-NMRV 025-130 F	
	NRV-NMRV 025-130	NRV-NMRV 025-130 F	
	PC-NMRV 063/040-090/130	PC-NMRV 063/040-090/130 F	

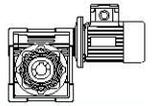

电机直联尺寸 Predisposition

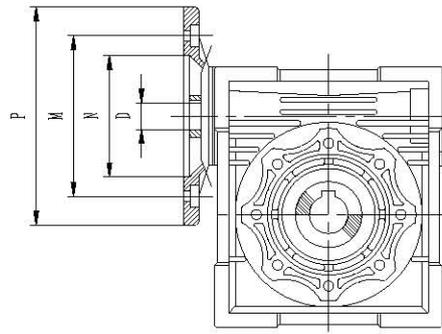

NMRV	PAM IEC	N	M	P	D											
					5	7.5	10	15	20	25	30	40	50	60	80	100
025	56B14	50	65	80	9	9	9	9	9	-	9	9	9	9	-	-
030	63B5	95	115	140	11	11	11	11	11	11	11	11	11	-	-	-
	63B14	60	75	90	9	9	9	9	9	9	9	9	9	9	9	-
	56B5	80	100	120	-	-	-	-	-	-	-	-	-	9	9	9
	56B14	50	65	80	-	-	-	-	-	-	-	-	-	-	-	-
040	71B5	110	130	160	14	14	14	14	14	14	14	14	-	-	-	-
	71B14	70	85	105	11	11	11	11	11	11	11	11	11	11	11	11
	63B5	95	115	140	-	-	-	-	-	-	-	-	-	9	9	9
	63B14	60	75	90	-	-	-	-	-	-	-	-	-	-	-	-
	56B5	80	100	120	-	-	-	-	-	-	-	-	-	-	-	-
050	80B5	130	165	200	19	19	19	19	19	19	19	-	-	-	-	-
	80B14	80	100	120	14	14	14	14	14	14	14	14	14	14	14	-
	71B5	110	130	160	-	-	-	-	-	-	-	11	11	11	11	11
	71B14	70	85	105	-	-	-	-	-	-	-	-	-	-	-	-
	63B5	95	115	140	-	-	-	-	-	-	-	-	-	-	-	-
063	90B5	130	165	200	-	24	24	24	24	24	24	-	-	-	-	-
	90B14	95	115	140	-	19	19	19	19	19	19	19	19	19	-	-
	80B5	130	165	200	-	-	-	-	-	-	-	14	14	14	14	14
	80B14	80	100	120	-	-	-	-	-	-	-	-	-	-	-	-
	71B5	110	130	160	-	-	-	-	-	-	-	-	-	-	-	-
	71B14	70	85	105	-	-	-	-	-	-	-	-	-	-	-	-
075	110/112B5	180	215	250	-	28	28	28	-	-	-	-	-	-	-	-
	110/112B14	110	130	160	-	24	24	24	24	24	24	24	-	-	-	-
	90B5	130	165	200	-	-	-	-	19	19	19	19	19	19	19	19
	90B14	95	115	140	-	-	-	-	-	-	-	-	-	-	-	-
	80B5	130	165	200	-	-	-	-	-	-	-	-	-	-	-	-
	80B14	80	100	120	-	-	-	-	-	-	-	-	-	-	-	-
	71B5	110	130	160	-	-	-	-	-	-	-	-	14	14	14	14
090	110/112B5	180	215	250	-	28	28	28	28	28	28	-	-	-	-	-
	110/112B14	110	130	160	-	24	24	24	24	24	24	24	24	24	-	-
	90B5	130	165	200	-	-	-	-	-	-	-	-	-	-	-	-
	90B14	95	115	140	-	-	-	-	-	-	-	-	-	-	-	-
	80B5	130	165	200	-	-	-	-	-	-	-	19	19	19	19	19
	80B14	80	100	120	-	-	-	-	-	-	-	-	-	-	-	-
110	132B5	230	265	300	-	38	38	38	38	-	-	-	-	-	-	-
	100/112B5	180	215	250	-	28	28	28	28	28	28	28	28	28	-	-
	90B5	130	165	200	-	-	-	-	-	24	24	24	24	24	24	24
	80B5	130	165	200	-	-	-	-	-	-	-	-	-	-	-	19
	80B14	80	100	120	-	-	-	-	-	-	-	-	-	-	-	-
130	132B5	230	265	300	-	38	38	38	38	38	38	38	-	-	-	-
	100/112B5	180	215	250	-	-	-	-	-	28	28	28	28	28	28	28
	90B5	130	165	200	-	-	-	-	-	-	-	-	-	-	24	24

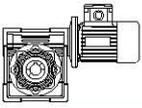

啮合参数表 Mesh data

蜗杆螺纹, 蜗轮齿牙, 效率

Worm thread, worm wheel tooth and efficiency data

NRV	i	5	7.5	10	15	20	25	30	40	50	60	80	100
025	Z1	4	4	3	2	2		1	1	1	1		
	γ	30° 57'	25° 18'	19° 31'	13° 18'	10° 53'		6° 44'	5° 29'	4° 34'	3° 56'		
	mx	1.8	1.3	1.3	1.3	1		1.3	1	0.8	0.67		
	η_d	0.86	0.84	0.82	0.78	0.74		0.66	0.61	0.57	0.54		
	η_s	0.71	0.70	0.67	0.60	0.55		0.46	0.41	0.36	0.34		
030	Z1	4	4	3	2	2	1	1	1	1	1	1	
	γ	21° 48'	18° 50'	14° 21'	9° 40'	7° 44'	5° 34'	4° 52'	3° 53'	3° 11'	2° 46'	2° 07'	
	mx	2	1.44	1.44	1.44	1.1	1.7	1.44	1.1	0.88	0.75	0.56	
	η_d	0.86	0.84	0.81	0.76	0.72	0.67	0.64	0.58	0.54	0.50	0.44	
	η_s	0.71	0.66	0.62	0.54	0.50	0.43	0.39	0.35	0.31	0.27	0.23	
040	Z1	4	4	4	2	2	2	1	1	1	1	1	1
	γ	27° 24'	21° 48'	17° 31'	11° 18'	8° 58'	7° 41'	5° 42'	4° 30'	3° 51'	3° 17'	2° 32'	2° 05'
	mx	2.8	2	1.5	2	1.5	1.25	2	1.5	1.25	1.04	0.78	0.63
	η_d	0.88	0.86	0.85	0.81	0.77	0.74	0.69	0.64	0.61	0.57	0.51	0.47
	η_s	0.72	0.69	0.65	0.58	0.53	0.5	0.44	0.4	0.36	0.32	0.28	0.24
050	Z1	4	4	4	2	2	2	1	1	1	1	1	1
	γ	23° 49'	21° 48'	17° 42'	11° 18'	9° 04'	7° 36'	5° 42'	4° 33'	3° 49'	3° 17'	2° 33'	2° 04'
	mx	3.4	2.5	1.9	2.5	1.9	1.54	2.5	1.9	1.54	1.3	0.98	0.78
	η_d	0.87	0.86	0.84	0.8	0.77	0.74	0.7	0.65	0.61	0.57	0.51	0.49
	η_s	0.73	0.69	0.65	0.58	0.54	0.5	0.44	0.39	0.35	0.32	0.27	0.23
063	Z1		4	4	2	2	2	1	1	1	1	1	1
	γ		24° 31'	20° 19'	12° 50'	10° 29'	8° 44'	6° 30'	5° 17'	4° 23'	3° 47'	2° 59'	2° 25'
	mx		3.25	2.5	3.25	2.5	2	3.25	2.5	2	1.68	1.28	1.02
	η_d		0.87	0.86	0.82	0.8	0.77	0.73	0.69	0.65	0.61	0.56	0.5
	η_s		0.7	0.65	0.59	0.54	0.5	0.45	0.4	0.36	0.33	0.28	0.24
075	Z1		4	4	2	2	2	1	1	1	1	1	1
	γ		26° 33'	21° 48'	14° 02'	11° 18'	9° 37'	7° 07'	5° 42'	4° 50'	4° 05'	3° 15'	2° 40'
	mx		4	3	4	3	2.45	4	3	2.45	2	1.54	1.24
	η_d		0.88	0.87	0.84	0.81	0.79	0.75	0.71	0.68	0.64	0.59	0.54
	η_s		0.7	0.67	0.6	0.57	0.52	0.46	0.42	0.38	0.35	0.29	0.26
090	Z1		4	4	2	2	2	1	1	1	1	1	1
	γ		28° 20'	23° 26'	15° 05'	12° 14'	10° 37'	7° 40'	6° 11'	5° 21'	4° 36'	3° 36'	2° 57'
	mx		4.8	3.6	4.8	3.6	3	4.8	3.6	3	2.5	1.88	1.5
	η_d		0.89	0.88	0.85	0.83	0.81	0.77	0.74	0.71	0.68	0.62	0.58
	η_s		0.72	0.69	0.63	0.59	0.55	0.49	0.45	0.41	0.38	0.32	0.28
110	Z1		4	4	2	2	2	1	1	1	1	1	1
	γ		28° 17'	27° 35'	15° 03'	14° 38'	12° 37'	7° 39'	7° 26'	6° 23'	5° 31'	4° 23'	3° 38'
	mx		5.89	4.6	5.89	4.6	3.75	5.89	4.6	3.75	3.12	2.36	1.9
	η_d		0.89	0.88	0.85	0.84	0.83	0.78	0.77	0.74	0.71	0.66	0.62
	η_s		0.71	0.68	0.62	0.61	0.58	0.48	0.48	0.44	0.41	0.36	0.32
130	Z1		4	4	2	2	2	1	1	1	1	1	1
	γ		28° 46'	26° 15'	15° 21'	13° 51'	11° 49'	7° 48'	7° 01'	5° 58'	5° 12'	4° 05'	3° 25'
	mx		7	5.4	7	5.4	4.37	7	5.4	4.37	3.68	2.75	2.24
	η_d		0.9	0.88	0.86	0.85	0.83	0.79	0.77	0.74	0.71	0.67	0.63
	η_s		0.71	0.68	0.62	0.6	0.57	0.49	0.46	0.43	0.39	0.34	0.3

The helix is right-handed. $\eta_d(1400)\dots$ dynamic efficiency at $n_1=1400$ $\eta_s\dots$ static efficiency

$i\dots$ ratio Z1:蜗杆齿数 γ :螺旋角 mx:模数

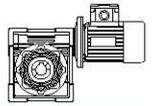

性能参数表 Performance

P1 (kW)	n2 (1/min)	M2 (Nm)	f. s.	i	减速机型号 Type	Fr2 (N)	页码 Page
0.06	280	1.8	6.2	5	NMRV025	439	24
	186.7	2.6	4.2	7.5		503	
	140	3.4	3.5	10		553	
	93.3	4.9	2.5	15		633	
	70	6.1	2	20		697	
	46.7	8.2	1.6	30		798	
	35	10	1.3	40		878	
	28	12	0.9	50		946	
	23.3	14	0.7	60	1006		
	280	1.8	10.1	5	NMRV030	597	25
	186.7	2.6	6.9	7.5		683	
	140	3.4	5.4	10		752	
	93.3	4.7	3.8	15		861	
	70	6	3	20		948	
	56	7	3	25		1021	
	46.7	8	2.5	30		1085	
	35	9.7	1.9	40		1194	
	28	11	1.5	50		1286	
	23.3	13	1.3	60		1367	
	17.5	14	0.9	80	1504		
	14	25.1	1.3	100	1620	NMRV025/030	48
	9.3	32	0.9	150	1830		
	7	41	0.7	200	1830		
	5.6	44	0.8	250	1830		
4.7	59.1	1.2	300	3490	NMRV025/040	48	
3.5	71	0.9	400	3490			
2.8	82	0.7	500	3490			
2.3	101	0.6	600	3490			
1.9	116	0.5	750	3490			
1.6	143	0.5	900	3490			
1.2	171	0.4	1200	3490			
0.9	197	0.3	1500	3490			
0.8	217	0.3	1800	3490			
0.6	268	0.2	2400	3490			
0.5	324	0.2	3000	3490			
0.4	294	0.1	4000	3490			
0.3	356	0.1	5000	3490			
4.7	57.4	1.3	300	3490	NMRV030/040	48	
3.5	70	0.9	400	3490			
2.8	96	0.6	500	3490			
2.3	104	0.7	600	3490			
1.9	121	0.6	750	3490			
1.6	139	0.5	900	3490			
1.2	166	0.4	1200	3490			
0.9	196	0.4	1500	3490			
0.8	218	0.3	1800	3490			
0.58	261	0.2	2400	3490			
0.4	300	0.2	3200	3490			
0.4	279	0.1	4000	3490			
0.28	338	0.1	5000	3490			
1.6	141.3	1	900	4840	NMRV030/050	49	
1.2	169	0.7	1200	4840			
0.93	199	0.7	1500	4840			
0.78	222	0.7	1800	4840			
0.6	266	0.5	2400	4840			
0.5	307	0.4	3000	4840			
0.35	288	0.3	4000	4840			
0.29	311	0.3	4800	4840			

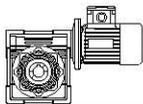

性能参数表 Performance

P1 (kW)	n2 (1/min)	M2 (Nm)	f. s.	i	减速机型号 Type	Fr2 (N)	页码 Page		
0.06	0.9	203.5	1.1	1500	NMRV030/063	6270	49		
	0.78	225	0.9	1800		6270			
	0.58	276	0.8	2400		6270			
	0.47	319	0.7	3000		6270			
	0.35	306	0.6	4000		6270			
	0.28	360	0.4	5000		6270			
	0.6	330.4	1.1	2400	NMRV040/075	7380	49		
	0.47	377	0.8	3000		7380			
	0.35	355	0.7	4000		7380			
	0.28	419	0.5	5000		7380			
	0.5	405.9	1.4	3000	NMRV040/090	8180	50		
	0.35	365	1.3	4000		8180			
0.28	431	1	5000	8180					
0.09	280	2.7	4.1	5	NMRV025	439	24		
	186.7	3.9	2.8	7.5		503			
	140	5.1	2.4	10		553			
	93.3	7.3	1.6	15		633			
	70	9.2	1.3	20		697			
	46.7	12	1.1	30		798			
	35	15	0.9	40		878			
	280	2.7	6.7	5		597		NMRV030	25
	186.7	3.9	4.6	7.5	683				
	140	5	3.6	10	752				
	93.3	7.1	2.5	15	861				
	70	9	2	20	948				
	56	10	2	25	1021				
	46.7	12	1.7	30	1085				
	35	14	1.2	40	1194				
	28	17	1	50	1286				
	23.3	19	0.9	60	1367				
	14	37.7	0.8	100	1620	NMRV025/030	48		
	9.3	49	0.6	150	1830				
	7	62	0.5	200	1830				
	5.6	66	0.5	250	1830				
	4.7	75	0.4	300	1830				
	3.5	107	0.3	400	1830				
	2.8	115	0.3	500	1830				
	2.3	135	0.2	600	1830				
	1.9	151	0.2	750	1830				
	1.6	178	0.2	900	1830				
	1.2	212	0.1	1200	1830				
	0.9	247	0.1	1500	1830				
	0.78	304	0.1	1800	1830				
	0.58	340	0.1	2400	1830				
	0.47	405	0.1	3000	1830				
	28	19	2	50	2475			NMRV040	26
	23.3	21	1.7	60	2630				
	17.5	26	1.3	80	2895				
	14	29	1	100	3118				
	4.7	87.6	0.8	300	3490	NMRV030/040	48		
	3.5	106.7	1.2	400	4840	NMRV030/050	49		
	2.8	123	1	500	4840				
	2.3	159	0.9	600	4840				
	1.9	185	0.8	750	4840				
	1.6	212	0.7	900	4840				
	1.6	200	1	900	6270				
	1.2	263	0.9	1200	6270	NMRV030/063	49		
	0.93	305	0.7	1500	6270				

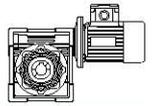

性能参数表 Performance

P1 (kW)	n2 (1/min)	M2 (Nm)	f. s.	i	减速机型号 Type	Fr2 (N)	页码 Page
0.09	0.9	359.7	1.1	1500		7380	
	0.78	404	1	1800	NMRV040/075	7380	49
	0.58	496	0.7	2400		7380	
	0.5	608.9	0.9	3000	NMRV040/090	8180	50
	0.35	548	0.8	4000		8180	
	0.12	280	3.6	5.1	5		597
186.7		5.2	3.4	7.5		683	
140		6.7	2.7	10		752	
93.3		9.5	1.9	15		861	
70		12	1.5	20	NMRV030	948	25
56		14	1.5	25		1021	
46.7		16	1.3	30		1085	
35		19	0.9	40		1194	
28		23	0.8	50		1286	
46.7		17.2	2.6	30		2087	
35		21	1.9	40		2298	
28		25	1.5	50		2475	
2.3		28	1.3	60	NMRV040	2630	26
17.5		34	1	80		2895	
14		38	0.8	100		3118	
19.1		41.5	1.2	73.3		2833	
15.9		45	1.2	88		3011	
11.9		56	0.9	117.3	PC063+NMRV040	3314	42
9.5		64.6	0.7	146.7		3490	
7.9		73	0.6	176		3490	
23.3		29	2.3	60		3610	
17.5		35	1.9	80	NMRV050	3973	27
14		40	1.4	100		4280	
9.5		66	1.3	146.7		4840	
7.9		74	1.1	176		4840	
6.0		85	0.8	234.6	PC063+NMRV050	4840	42
4.8		96	0.7	293.3		4840	
4.7		118.8	1.2	300		4840	
3.5		142	0.9	400	NMRV030/050	4840	49
2.8		164	0.7	500		4840	
6.0		89	1.5	234.6		6270	
4.8		101	1.2	293.3	PC063+NMRV063	6270	42
2.8		171.2	1.3	500		6270	
2.3		208	1.1	600	NMRV030/063	6270	49
1.9		241	0.9	750		6270	
1.6		324.9	1.2	900		7370	
1.2	399	0.9	1200	NMRV040/075	7380	49	
0.8	546.6	0.9	1800		8180		
0.58	695	0.9	2400	NMRV040/090	8180	50	
0.5	883.8	1.2	3000		10320		
0.35	784	1	4000	NMRV050/110	10320	50	
0.28	928	0.8	5000		10320		
0.18	280	5.3	3.4	5		597	
	186.7	7.8	2.3	7.5		683	
	140	10	1.8	10		752	
	93.3	14	1.3	15		861	
	70	18	1	20	NMRV030	948	25
	56	21	1	25		1021	
	46.7	24	0.8	30		1085	
	70	19.2	2	20		1824	
	56	23	1.7	25		1964	
	46.7	26	1.7	30	NMRV040	2087	26
	35	32	1.3	40		2298	

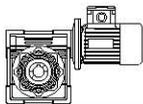

性能参数表 Performance

P1 (kW)	n2 (1/min)	M2 (Nm)	f. s.	i	减速机型号 Type	Fr2 (N)	页码 Page
0.18	28	38	1	50	NMRV040	2475	26
	23.3	43	0.8	60		2630	
	19.1	62	0.8	73.3	PC063+NMRV040	2833	42
	15.9	69	0.8	88		3011	
	11.9	84	0.6	117.3		3314	
	35	32.9	2.3	40		3153	
	28	39	1.9	50	NMRV050	3397	27
	23.3	43	1.6	60		3610	
	17.5	52	1.2	80		3973	
	14	60	0.9	100		4280	
	19.1	62	1.4	73.3	PC063+NMRV050	3889	42
	15.9	70	1.5	88		4132	
	11.9	86	1.1	117.3		4548	
	9.5	99	0.9	146.7		4840	
	7.9	112	0.7	176		4840	
	6.0	129	0.6	234.6		4840	
	9.5	101	1.7	146.7	PC063+NMRV063	6270	42
	7.9	116	1.4	176		6270	
	6.0	135	1	234.6		6270	
	4.8	152	0.8	293.3		6270	
3.5	221.5	1	400	NMRV030/063	6270	49	
2.8	257	0.8	500		6270		
2.3	362	1.1	600	NMRV040/075	7380	49	
1.9	435	0.9	750		7380		
1.6	487	0.8	900		7380		
1.2	629.2	1	1200	NMRV040/090	8180	50	
0.93	735	0.8	1500		8180		
0.8	860.6	1.5	1800	NMRV050/110	10320	50	
0.58	1113	1.1	2400		10320		
0.22	280	6.5	2.8	5	NMRV030	597	25
	186.7	10	1.9	7.5		683	
	140	12	1.5	10		752	
	93.3	17	1	15		861	
	70	22	0.8	20	948	NMRV040	26
	93.3	18.5	2.2	15	1657		
	70	23	1.7	20	1824		
	56	28	1.4	25	1964		
	46.7	32	1.4	30	2087		
	35	39	1.1	40	2298		
	28	47	0.8	50	2475	NMRV050	27
	28	47.3	1.5	50	3397		
	23.3	53	1.3	60	3610		
	17.5	64	1	80	3973		
	19.1	76	1.2	73.3	PC063+NMRV050	3889	42
	15.9	84	1.2	88		4132	
	11.9	104	0.9	117.3		4548	
	9.5	123	1.4	146.7		6270	
	7.9	141	1.1	176		6270	
	4.7	210.5	1.1	300		6270	
3.5	271	0.8	400	NMRV030/063	6270	49	
0.25	280	7.6	4.5	5	NMRV040	1149	26
	186.7	11	3.6	7.5		1315	
	140	14	2.8	10		1447	
	93.3	21	1.9	15		1657	
	70	27	1.5	20		1824	
	56	32	1.2	25		1964	
	46.7	36	1.3	30		2087	
	35	44	0.9	40		2298	

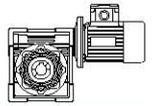

性能参数表 Performance

P1 (kW)	n2 (1/min)	M2 (Nm)	f. s.	i	减速机型号 Type	Fr2 (N)	页码 Page
0.25	70	26.9	2.7	20	NMRV050	2503	27
	56	32	2.2	25		2696	
	46.7	37	2.3	30		2865	
	35	46	1.7	40		3153	
	28	54	1.4	50		3397	
	23.3	60	1.1	60		3610	
	17.5	72	0.9	80		3973	
	19.1	86	1	73.4		PC071+NMRV050	
	15.9	96	1.1	88.1	4132		
	11.9	119	0.8	117.5	4548		
	28	56.3	2.4	50	NMRV063	4440	28
	23.3	63	2	60		4719	
	17.5	78	1.6	80		5193	
	14	87	1.4	100		5595	
	19.1	89	1.8	73.4	PC071+NMRV063	5083	43
	15.9	98	2	88.1		5401	
	11.9	123	1.5	117.5		5945	
	9.5	140	1.2	146.9		6270	
	7.9	161	1	176.3		6270	
	6.0	185.6	0.7	235		6270	
	4.8	211	0.6	293.8		6270	
	7	159.5	1.4	400		NMRV030/063	
	5.6	185	1.2	500	6270		
	17.5	81.9	2.3	80	NMRV075	6130	29
	14	94	1.9	100		6603	
	9.5	148	1.7	146.9	PC071+NMRV075	7380	43
	7.9	170	1.4	176.3		7380	
	6.0	195	1.1	235		7380	
4.8	225	0.9	293.8	7380			
3.5	336.3	1.1	400	NMRV040/075	7380	49	
2.8	384	0.8	500		7380		
2.3	511.8	1.2	600	NMRV040/090	8180	50	
1.9	598	0.9	750		8180		
1.6	667	0.8	900		8180		
1.2	943	1.3	1200	NMRV050/110	10320	50	
0.93	1064	1.2	1500		10320		
0.78	1195	1.1	1800		10320		
0.6	1624	1	2400	NMRV063/130	13500	50	
0.47	1935	0.8	3000		13500		
0.35	2046	0.6	4000		13500		
0.28	2430	0.5	5000		13500		
280	11.2	3	5		NMRV040		1149
186.7	16	2.4	7.5	1315			
140	21	1.9	10	1447			
93.3	31	1.3	15	1657			
70	39	1	20	1824			
56	47	0.8	25	1964			
46.7	53	0.8	30	2087			
140	21.7	3.3	10	NMRV050		1987	27
93.3	31	2.4	15		2274		
70	40	1.8	20		2503		
56	48	1.5	25		2696		
46.7	55	1.5	30		2865		
35	68	1.1	40		3153		
28	80	0.9	50		3397		
23.3	89	0.8	60		3610		
35	70.7	2.1	40	NMRV063	4122	28	
28	83	1.6	50		4440		

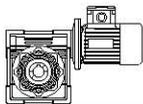

性能参数表 Performance

P1 (kW)	n2 (1/min)	M2 (Nm)	f. s.	i	减速机型号 Type	Fr2 (N)	页码 Page
0.37	23.3	94	1.4	60		4719	
	17.5	115	1.1	80	NMRV063	5193	28
	14	129	0.9	100		5595	
	19.1	131	1.2	73.4		5083	
	15.9	145	1.4	88.1	PC071+NMRV063	5401	43
	11.9	182	1	117.5		5945	
	9.5	208	0.8	146.9		6270	
	23.3	98.4	2	60		5569	
	17.5	121	1.6	80	NMRV075	6130	29
	14	139	1.3	100		6603	
	19.1	135	1.8	73.4		6000	
	15.9	151	1.9	88.1		6375	
	11.9	188	1.5	117.5	PC071+NMRV075	7017	43
	9.5	218	1.1	146.9		7380	
	7.9	251	0.9	176.3		7380	
	4.7	405.5	1	300		7380	
	3.5	498	0.7	400	NMRV040/075	7380	49
	7.9	265	1.5	176.3		8180	
	6.0	312	1.1	235	PC071+NMRV090	8180	43
	4.8	363	0.9	293.8		8180	
4.7	401.8	1.5	300		8180		
3.5	523	1.2	400		8180		
2.8	611	0.9	500	NMRV040/090	8180	50	
2.3	757	0.8	600		8180		
1.9	949.5	1.3	750		10320		
1.6	1079	1.2	900	NMRV050/110	10320	50	
1.2	1396	0.8	1200		10320		
0.9	1674.1	1.1	1500		13500		
0.78	1887	0.9	1800	NMRV063/130	13500	50	
0.55	280	16.7	2	5		1149	
	186.7	24	1.6	7.5		1315	
	140	32	1.3	10	NMRV040	1447	26
	93.3	46	0.9	15		1657	
	280	16.7	3.7	5		1577	
	186.7	25	2.9	7.5		1805	
	140	32	2.2	10		1987	
	93.3	46	1.6	15		2274	
	70	59	1.2	20	NMRV050	2503	27
	56	71	1	25		2696	
	46.7	81	1	30		2865	
	70	60.8	2.2	20		3272	
	56	73	1.8	25		3524	
	46.7	83	1.9	30		3745	
	35	105	1.4	40	NMRV063	4122	29
	28	124	1.1	50		4440	
	23.3	140	0.9	60		4719	
	19.1	196	0.8	73.4		5083	
	15.9	215	0.9	88.1	PC071+NMRV063	5401	43
	35	108.1	2	40		4865	
28	129	1.6	50		5241		
23.3	146	1.4	60		5569		
17.5	180	1.1	80	NMRV075	6130	29	
14	206	0.9	100		6603		
19.1	201	1.2	73.4		6000		
15.9	229	1.3	88.1		6375		
11.9	279	1	176.3	PC071+NMRV075	7017	43	
18.7	205.4	1.2	75		6000		
15.6	230	1.3	90	PC080+NMRV075	6375	44	

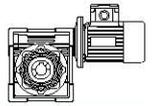

性能参数表 Performance

P1 (kW)	n2 (1/min)	M2 (Nm)	f. s.	i	减速机型号 Type	Fr2 (N)	页码 Page
0.55	11.7	284	1	120	PC080+NMRV075	7017	44
	9.3	332	0.8	150		7380	
	17.5	189.1	1.5	80	NMRV090	6783	30
	14	221	1.2	100		7306	
	15.6	239.7	2.3	90	PC080+NMRV090	7054	44
	11.7	297	1.6	120		7764	
	9.3	355	1.3	150		8180	
	7.8	398	1	180		8180	
	5.8	477	0.8	240		8180	
	17.5	201.1	2.6	80	NMRV110	8571	31
	14	236	2	100		9232	
	7.8	425.5	1.8	180	PC080+NMRV110	10320	44
	5.8	513	1.3	240		10320	
	4.7	597	1	300		10320	
	4.7	638.9	2	300	NMRV050/110	10320	50
	3.5	826	1.4	400		10320	
	2.8	984	1.1	500		10320	
	2.3	1181	1	600		10320	
	1.9	1411	0.9	750		10320	
	2.8	995.5	1.6	500		13500	
1.9	1471	1.2	750	NMRV063/130	13500	50	
1.2	2132	0.8	1200		13500		
0.75	280	22.8	2.7	5	NMRV050	1577	27
	186.7	34	2.1	7.5		1805	
	140	44	1.6	10		1987	
	93.3	63	1.2	15		2274	
	70	81	0.9	20		2503	
	93.3	63.7	2.2	15	NMRV063	2973	28
	70	83	1.6	20		3272	
	56	100	1.3	25		3524	
	46.7	114	1.4	30		3745	
	35	143	1	40		4122	
	56	102.3	2	25	NMRV075	4160	29
	46.7	117	2	30		4421	
	35	147	1.5	40		4865	
	28	177	1.2	50		5241	
	23.3	200	1	60		5569	
	18.7	280.1	0.9	75	PC080+NMRV075	6000	44
	15.6	313	1	90		6375	
	28	184.2	1.8	50	NMRV090	5799	30
	23.3	212	1.5	60		6163	
	17.5	258	1.1	80		6783	
	14	302	0.9	100		7306	
	15.6	326.9	1.7	90		7054	
	11.7	405	1.2	120	PC080+NMRV090	7764	44
	9.3	483	0.9	150		8180	
	7.8	543	0.7	180		8180	
	17.5	274.2	1.9	80		8571	
	14	322	1.5	100	NMRV110	9232	31
	11.7	429.8	2.2	120	PC080+NMRV110	9811	44
	9.3	506	1.7	150		10320	
	7.8	580	1.3	180		10320	
5.8	700	0.9	240	10320			
4.7	871.2	1.5	300	10320			
3.5	1126	1.1	400	NMRV050/110	10320	50	
5.8	712.2	1.4	240	PC080+NMRV130	13500	44	
4.7	813	1.1	300		13500		
2.8	1357.5	1.1	500		NMRV063/130		13500

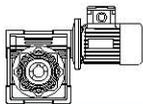

性能参数表 Performance

P1 (kW)	n2 (1/min)	M2 (Nm)	f. s.	i	减速机型号 Type	Fr2 (N)	页码 Page
0.75	2.3	1631	1	600		13500	
	1.9	2005	0.9	750	NMRV063/130	13500	50
	1.6	2283	0.8	900		13500	
1.1	186.7	49.5	2.6	7.5		2359	
	140	65	2	10		2597	
	93.3	93	1.5	15	NMRV063	2973	28
	70	122	1.1	20		3272	
	56	146	0.9	25		3524	
	46.7	167	1	30		3745	
	93.3	95.7	2.1	15		3509	
	70	123	1.7	20		3862	
	56	150	1.3	25	NMRV075	4160	29
	46.7	171	1.3	30		4421	
	35	216	1	40		4865	
	35	225.1	1.6	40		5383	
	28	270	1.3	50	NMRV090	5799	30
	23.3	311	1	60		6163	
	28	281.4	2.3	50		7328	
	23.3	324	1.9	60	NMRV110	7787	31
	17.5	402	1.3	80		8571	
	14	473	1	100		9232	
	19	398	2.5	73.6		8298	
	14.3	515	1.8	98.2		9133	
	11.4	609	1.5	122.7	PC090+NMRV110	9838	44
9.5	693	1.1	147.3		10320		
7.1	840	0.8	196.4		10320		
17.5	408.2	2.1	80	NMRV130	11210	32	
14	480	1.5	100		12076		
19	404	3.5	73.6		10853		
14.3	515	2.6	98.2		11945		
11.4	619	2	122.7	PC090+NMRV130	12868	44	
9.5	693	1.6	147.3		13500		
7.1	855	1.2	196.4		13500		
5.7	978	0.9	245.5		13500		
4.7	1312.1	1.3	300		13500		
3.5	1671	1	400	NMRV063/130	13500	50	
2.8	1991	0.8	500		13500		
1.5	186.7	67.5	1.9	7.5		2359	
	140	89	1.5	10		2597	
	93.3	127	1.1	15	NMRV063	2973	28
	70	166	0.8	20		3272	
	140	90	2.2	10		3065	
	93.3	130	1.5	15		3509	
	70	168	1.3	20	NMRV075	3862	29
	56	205	1	25		4160	
	46.7	233	1	30		4421	
	70	171.9	2.1	20		4273	
	56	210	1.6	25		4603	
	46.7	239	1.7	30		4891	
	35	307	1.2	40	NMRV090	5383	30
	28	368	0.9	50		5799	
	23.3	424	0.8	60		6163	
	35	319.2	2.2	40		6803	
	28	384	1.7	50		7328	
	23.3	442	1.4	60	NMRV110	7787	31
	17.5	548	0.9	80		8571	
	19	543	1.9	73.6		8298	
	14.3	703	1.3	98.2	PC090+NMRV110	9133	44

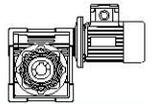

性能参数表 Performance

P1 (kW)	n2 (1/min)	M2 (Nm)	f. s.	i	减速机型号 Type	Fr2 (N)	页码 Page	
1.5	11.4	831	1.1	122.7	PC090+NMRV110	9838	44	
	9.5	946	0.8	147.3		10320		
	17.5	556.6	1.5	80	NMRV130	11210	32	
	14	655	1.1	100		12076		
	19	550	2.6	73.6	PC090+NMRV130	10853	44	
	14.3	703	1.9	98.2		11945		
	11.4	845	1.5	122.7	NMRV063/130	12868	50	
	9.5	998	1.1	147.3		13500		
	7.1	1165	0.8	196.4	13500			
	4.7	1789.3	1	300	NMRV075	13500	29	
	3.5	2279	0.7	400		13500		
	2.2	186.7	100.2	1.8	7.5	NMRV090	2785	30
		140	132	1.5	10		3065	
		93.3	191	1	15	NMRV110	3509	31
186.7		101.3	2.9	7.5	3081			
140		134	2.3	10	NMRV130	3391	32	
93.3		194	1.9	15		3882		
70		252	1.4	20	NMRV110	4273	31	
56		308	1.1	25		4603		
46.7		351	1.2	30	NMRV130	4891	32	
70		255.1	2.5	20		5399		
56		315	2.2	25	NMRV110	5816	31	
46.7		356	2	30		6181		
35		468	1.5	40	NMRV130	6803	32	
28		563	1.2	50		7328		
23.3		648	1	60	NMRV110	7787	31	
35		468.2	2.2	40		8897		
28		563	1.7	50	NMRV130	9584	32	
23.3		648	1.4	60		10185		
17.5	816	1	80	NMRV110	11210			
3	186.7	136.6	1.4	7.5	NMRV075	2785	29	
	140	180	1.1	10		3065		
	93.3	261	0.8	15	NMRV090	3509	30	
	186.7	138.1	2.1	7.5		3081		
	140	182	1.7	10	NMRV110	3391	31	
	93.3	264	1.4	15		3882		
	70	344	1	20	NMRV130	4273	32	
	56	420	0.8	25		4603		
	46.7	479	0.9	30	NMRV110	4891	31	
	93.3	264	2.5	15		4905		
	70	348	1.9	20	NMRV130	5399	32	
	56	430	1.6	25		5816		
	46.7	485	1.5	30	NMRV110	6181	31	
	35	638	1.1	40		6803		
	28	767	0.9	50	NMRV130	7328	32	
	56	429.8	2.2	25		7607		
	46.7	491	2.1	30	NMRV110	8084	31	
	35	638	1.6	40		8897		
28	767	1.3	50	NMRV130	9584	32		
23.3	884	1	60		10185			
17.5	1113	0.8	80	NMRV110	11210			
4	186.7	184.2	1.6	7.5	NMRV090	3081	30	
	140	243	1.3	10		3391		
	93.3	352	1	15	NMRV110	3882	31	
	70	458	0.8	20		4273		
	140	242.8	2.5	10	NMRV130	4285	32	
	93.3	352	1.9	15		4905		
70	464	1.4	20	NMRV110	5399			

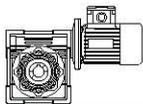

性能参数表 Performance

P1 (kW)	n2 (1/min)	M2 (Nm)	f. s.	i	减速机型号 Type	Fr2 (N)	页码 Page
4	56	573	1.2	25	NMRV110	5816	31
	46.7	647	1.1	30		6181	
	56	573	1.6	25	NMRV130	7607	32
	46.7	655	1.6	30		8084	
	35	851	1.2	40		8897	
28	1023	1	50	9584			
23.3	1179	0.8	60	10185			
4.8	186.7	221	1.3	7.5	NMRV090	3081	30
	140	291	1.1	10		3391	
	93.3	422	0.9	15		3882	
	186.7	221	2.5	7.5	NMRV110	3893	31
	140	291	2.1	10		4285	
	93.3	422	1.6	15		4905	
	70	557	1.2	20		5399	
	56	688	1	25		5816	
	56	687.6	1.4	25		7607	
	46.7	786	1.3	30		8084	
35	1022	1	40	8897			
28	1228	0.8	50	9584			
5.5	186.7	253.2	2.2	7.5	NMRV110	3893	31
	140	334	1.8	10		4285	
	93.3	484	1.4	15		4905	
	70	638	1	20		5399	
	140	333.9	2.5	10	NMRV130	5605	32
	93.3	490	1.9	15		6416	
	70	645	1.4	20		7062	
	56	788	1.2	25		7607	
	46.7	900	1.2	30		8084	
	35	1171	0.9	40		8897	
7.5	186.7	345.3	1.6	7.5	NMRV110	3893	31
	140	455	1.3	10		4285	
	93.3	660	1	15		4905	
	186.7	349.2	2.1	7.5	NMRV130	5092	32
	140	455	1.8	10		5605	
	93.3	668	1.4	15		6416	
	70	880	1	20		7062	
	56	1074	0.9	25		7607	
	46.7	1228	0.8	30		8084	
	35	1596	0.7	40		8897	
9.2	186.7	423.6	1.3	7.5	NMRV110	3893	31
	186.7	428.3	1.8	7.5	NMRV130	5092	32
	140	559	1.5	10		5605	
	93.3	819	1.1	15		6416	
	70	1079	0.8	20		7062	
	56	1318	0.7	25		7607	

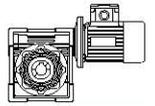

NRV性能参数表 Performance

(n1=1400)

M2 (Nm)	i	P1 (kW)	n2 (1/min)	减速机型号 Type	Fr2 (N)	Fr1 (N)	页码 Page
18	5	0.6	280	NRV030	597	150	25
18	7.5	0.4	186.7		683	150	
18	10	0.3	140		752	169	
18	15	0.2	93.3		861	169	
18	20	0.2	70		948	190	
21	25	0.2	56		1021	210	
20	30	0.2	46.7		1085	210	
18	40	0.1	35		1194	210	
17	50	0.1	28		1286	210	
16	60	0.1	23.3		1367	210	
13	80	0.1	17.5		1504	210	
34	5	1.1	280	NRV040	1149	250	26
40	7.5	0.9	186.7		1315	294	
40	10	0.7	140		1447	331	
40	15	0.5	93.3		1657	331	
39	20	0.4	70		1824	350	
38	25	0.3	56		1964	350	
45	30	0.3	46.7		2087	350	
41	40	0.2	35		2298	350	
39	50	0.2	28		2475	350	
36	60	0.2	23.3		2630	350	
33	80	0.1	17.5		2895	350	
29	100	0.1	14	3118	350		
62	5	2	280	NRV050	1577	350	27
71	7.5	1.6	186.7		1805	401	
72	10	1.2	140		1987	490	
74	15	0.9	93.3		2274	490	
73	20	0.7	70		2503	490	
70	25	0.5	56		2696	490	
84	30	0.6	46.7		2865	490	
76	40	0.4	35		3153	490	
73	50	0.3	28		3397	490	
68	60	0.3	23.3		3610	490	
65	80	0.2	17.5		3973	490	
55	100	0.2	14	4280	490		
128	7.5	2.8	186.7	NRV063	2359	500	28
130	10	2.2	140		2597	571	
140	15	1.6	93.3		2973	615	
135	20	1.2	70		3272	667	
130	25	1	56		3524	700	
160	30	1.1	46.7		3745	700	
145	40	0.8	35		4122	700	
135	50	0.6	28		4440	700	
130	60	0.5	23.3		4719	700	
122	80	0.4	17.5		5193	700	
118	100	0.3	14		5595	700	
185	7.5	4.1	186.7	NRV075	2785	700	29
195	10	3.2	140		3065	830	
200	15	2.3	93.3		3509	851	
210	20	1.9	70		3862	980	
200	25	1.5	56		4160	980	
230	30	1.5	46.7		4421	980	
220	40	1.1	35		4865	980	
210	50	0.9	28		5241	980	
200	60	0.8	23.3		5569	980	
190	80	0.6	17.5		6130	980	
180	100	0.5	14		6603	980	

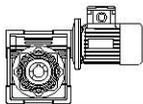

NRV性能参数表 Performance

(n1=1400)

M2 (Nm)	i	P1 (kW)	n2 (1/min)	减速机型号 Type	Fr2 (N)	Fr1 (N)	页码 Page
290	7.5	6.3	186.7	NRV090	3081	900	30
310	10	5.1	140		3391	1082	
360	15	4.1	93.3		3882	1257	
355	20	3.1	70		4273	1270	
340	25	2.4	56		4603	1270	
410	30	2.6	46.7		4891	1270	
360	40	1.8	35		5383	1270	
340	50	1.4	28		5799	1270	
320	60	1.1	23.3		6163	1270	
285	80	0.8	17.5		6783	1270	
270	100	0.7	14	7306	1270		
552	7.5	12	186.7	NRV110	3893	1200	31
598	10	9.8	140		4285	1463	
656	15	7.5	93.3		4905	1604	
644	20	5.6	70		5399	1700	
679	25	4.7	56		5816	1700	
725	30	4.5	46.7		6181	1700	
702	40	3.3	35		6803	1700	
660	50	2.6	28		7328	1700	
616	60	2.1	23.3		7787	1700	
515	80	1.4	17.5		8571	1700	
483	100	1.1	14	9232	1700		
750	7.5	16.1	186.7	NRV130	5092	1500	32
820	10	13.5	140		5605	1845	
920	15	10.3	93.3		6416	2070	
910	20	7.8	70		7062	2100	
930	25	6.5	56		7607	2100	
1040	30	6.4	46.7		8084	2100	
1050	40	4.9	35		8897	2100	
980	50	3.8	28		9584	2100	
900	60	3.1	23.3		10185	2100	
840	80	2.3	17.5		11210	2100	
740	100	1.7	14	12076	2100		

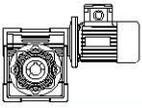

NMRV/NRV

NMRV

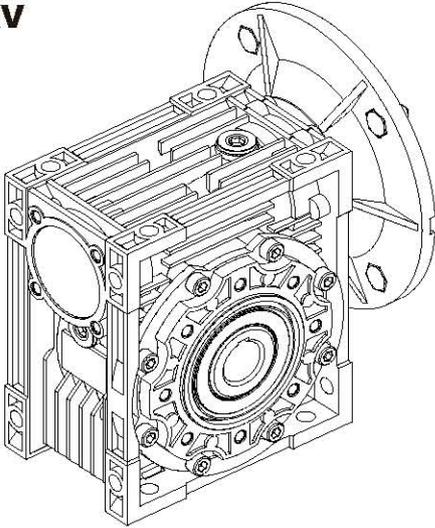

NRV

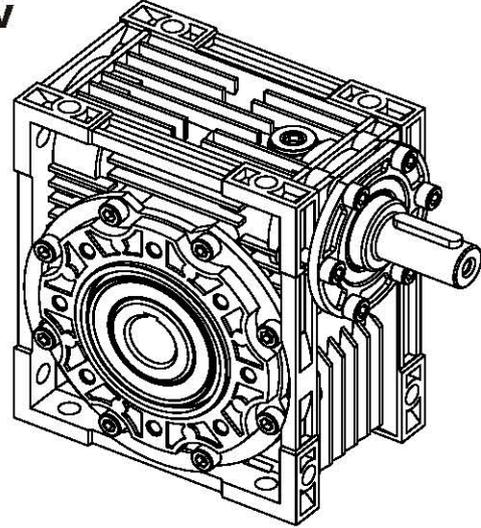

NMRV型号标记 NMRV Model & marker

NMRV-063-30-VS-F1(FA)-AS-80B5-0.75kW-B3

NMRV	蜗轮减速器 Worm geared motor		
NRV	蜗轮减速器(配接输入轴) Worm reduction unit		
063	蜗轮减速器中心距 Center distance		
30	减速比 Reduction ratio		
VS	双向输入轴 Double input shaft	F1(FA)	输出法兰位置及型号 Output flange
AS	单向输出轴 Single output shaft	AB	双向输出轴 Double output shaft
PAM	电机联接 Fitted for motor coupling	80B5	电机机座号和安装结构形式 Motor mounting facility
0.75kW	电机功率 Electric motor power	B3	安装方位 Mounting position

安装方位 Mounting positions

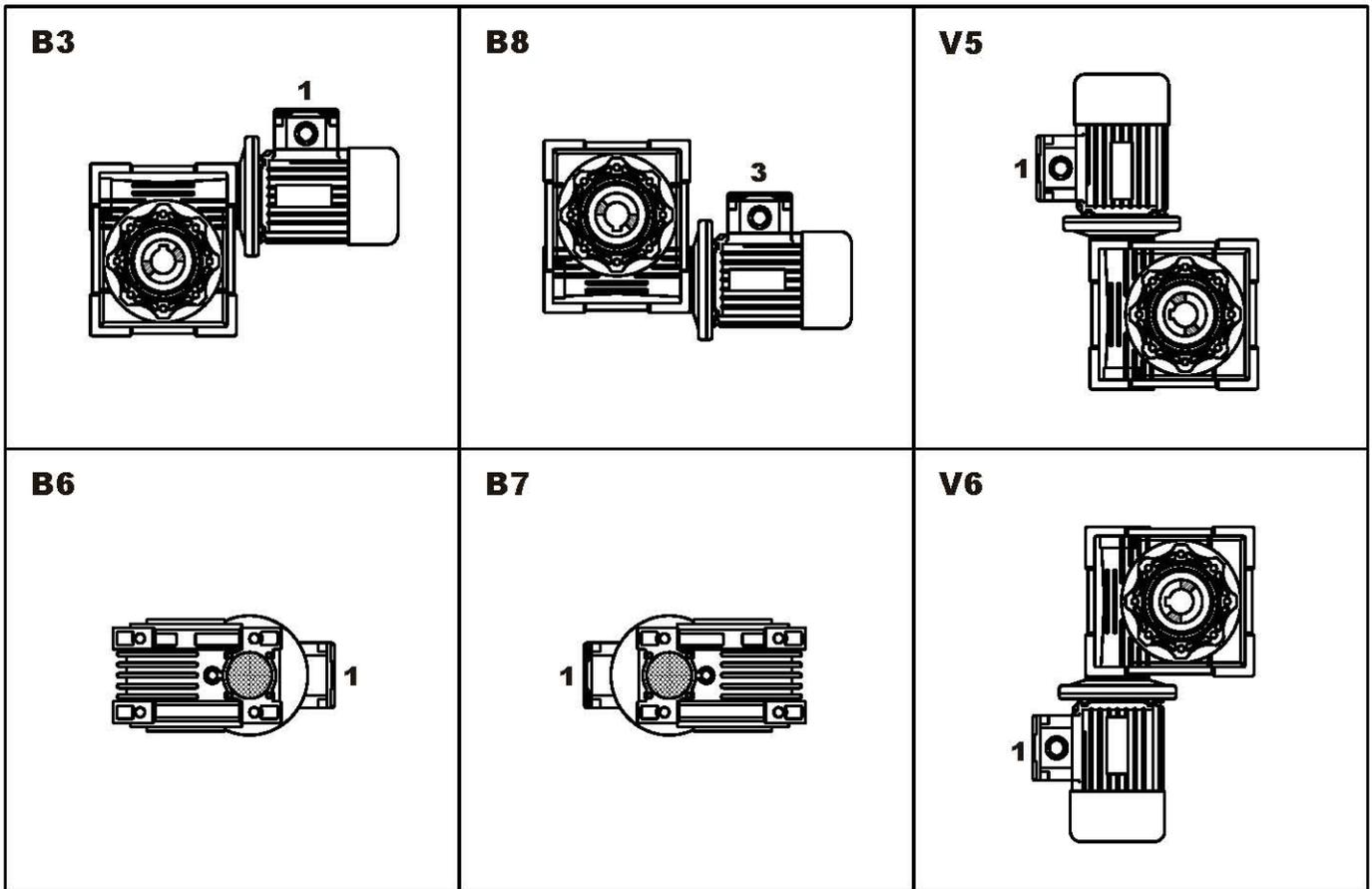

法兰位置 Flange F-FL

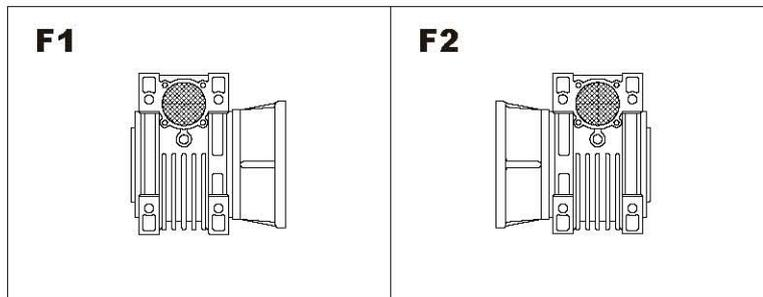

接线盒安装方式 Pos. of terminal box

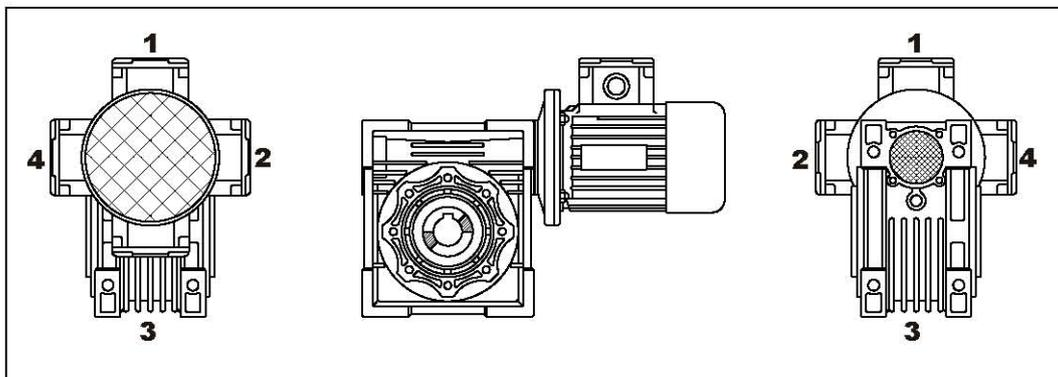

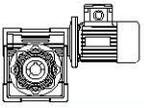

输出轴配置 Pos. of output shaft

AS1

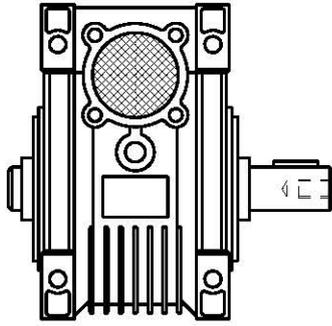

AS2

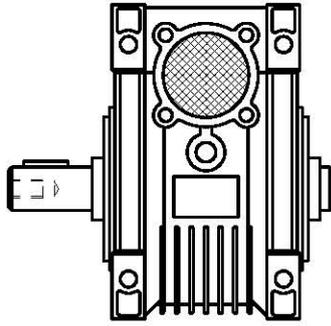

AB

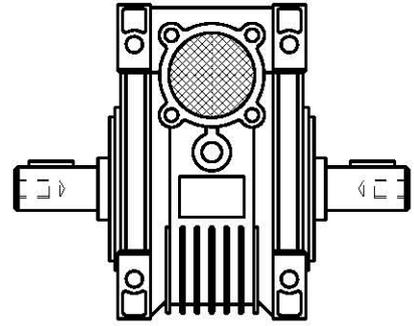

双向输入轴 Double extension worm shaft

VS

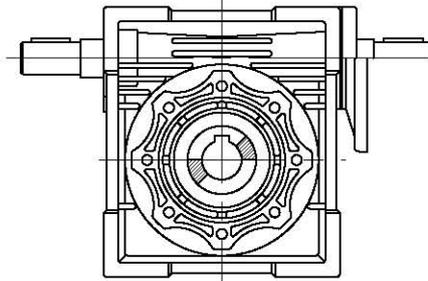

扭力臂配置 Pos. of torque arm

A1

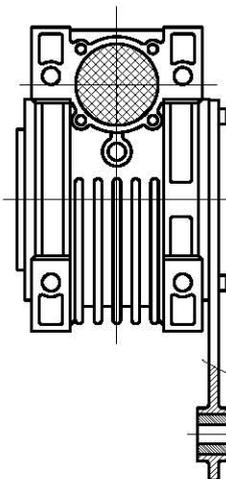

A2

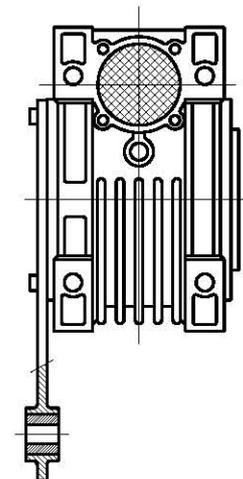

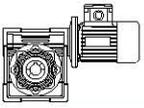

减速机外形尺寸 Dimensions

NMRV025

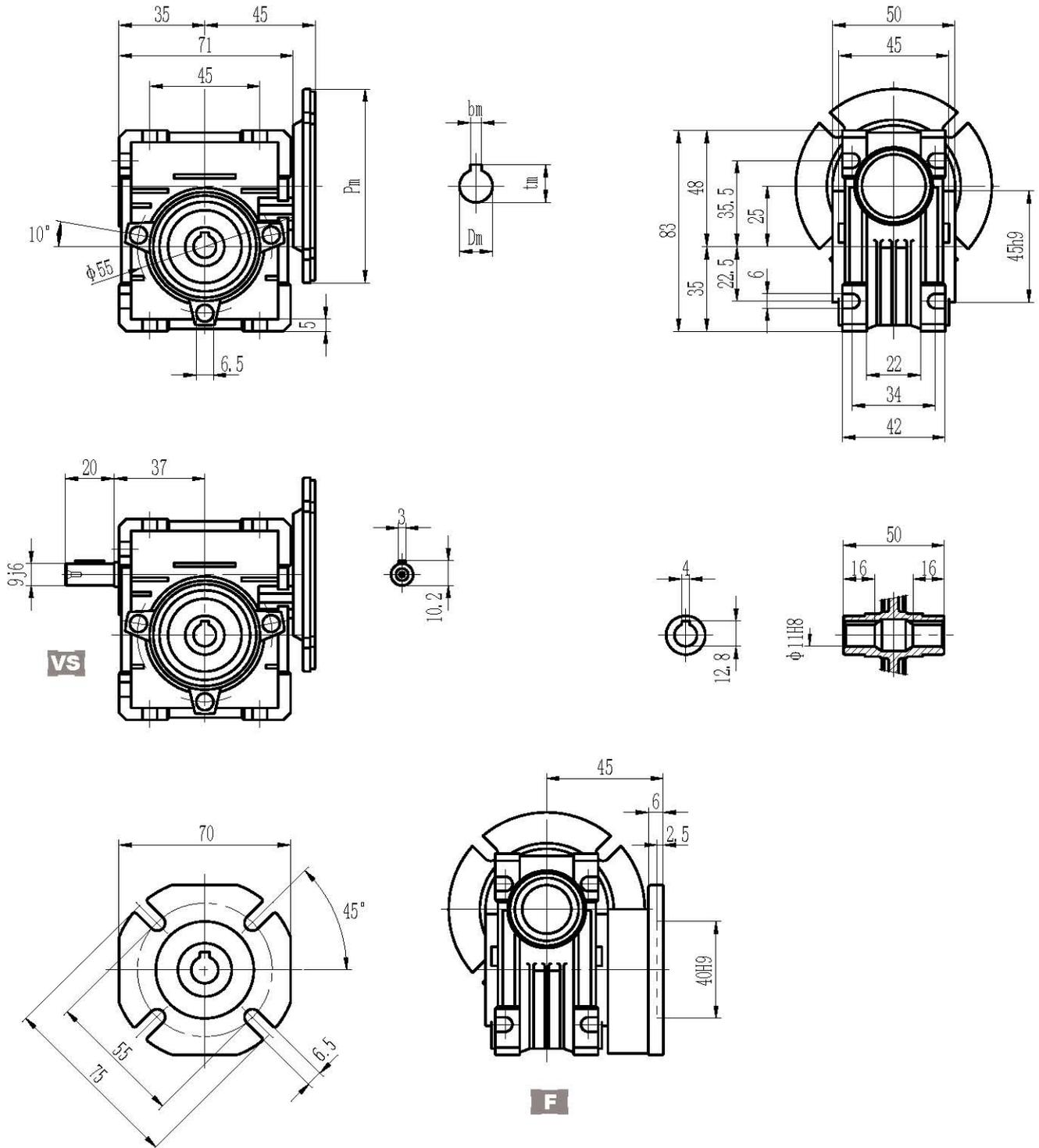

*不带电机重量为:0.7kg

*输入尺寸 (P_m , D_m , b_m , t_m) 参照第52页图表

*Weight without motor:0.7kg

*for the dimensions concerning the motor connection area(P_m , D_m , b_m , t_m)please refer to the table shown at page 52

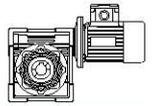

减速机外形尺寸 Dimensions

NMRV030

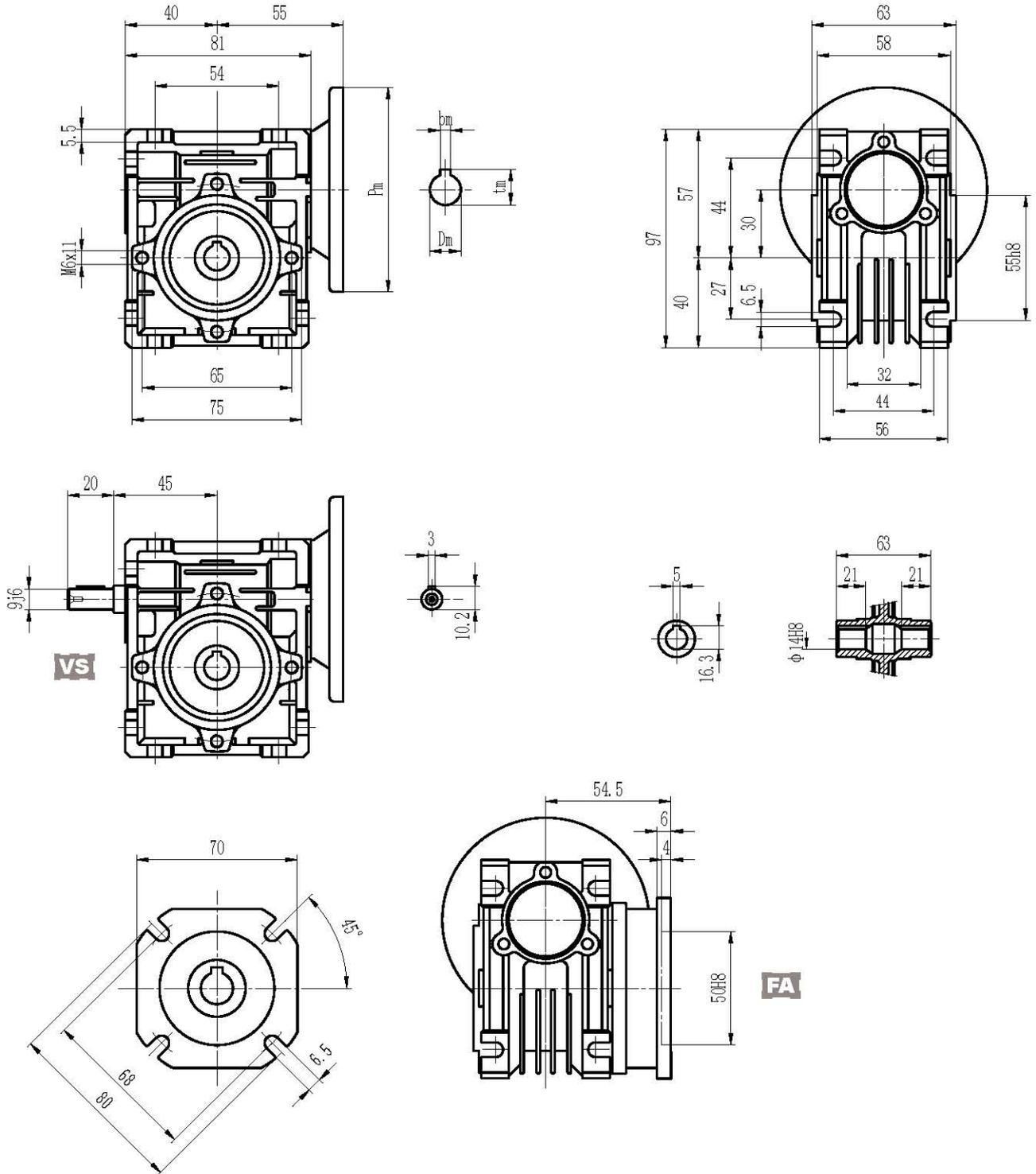

*不带电机重量为:1.2kg

*输入尺寸 (P_m, D_m, b_m, t_m) 参照第52页图表

*Weight without motor:1.2kg

*for the dimensions concerning the motor connection area(P_m, D_m, b_m, t_m)please refer to the table shown at page 52

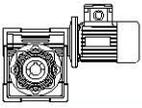

减速机外形尺寸 Dimensions

NMRV040

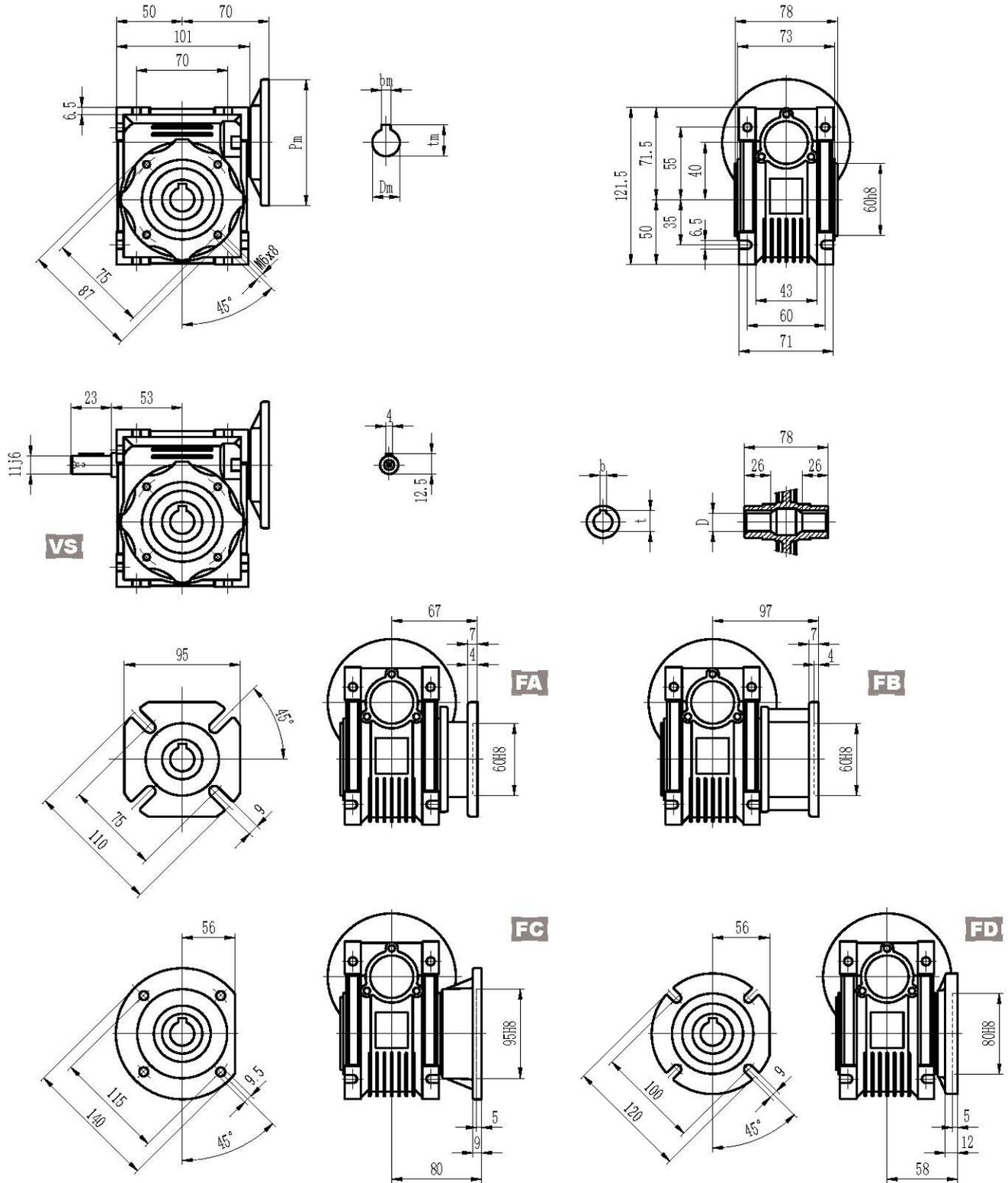

输出/Output		
D H8	b	t
18	6	20.8
(19)	(6)	(21.8)

(..) 根据用户要求定制
 *不带电机重量为:2.3kg
 *输入尺寸 (Pm, Dm, bm, tm) 参照第52页图表
 (..) Only on request
 *Weight without motor:2.3kg
 *for the dimensions concerning the motor connection area(Pm, Dm, bm, tm) please refer to the table shown at page 52

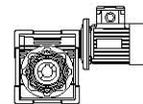

减速机外形尺寸 Dimensions

NMRV050

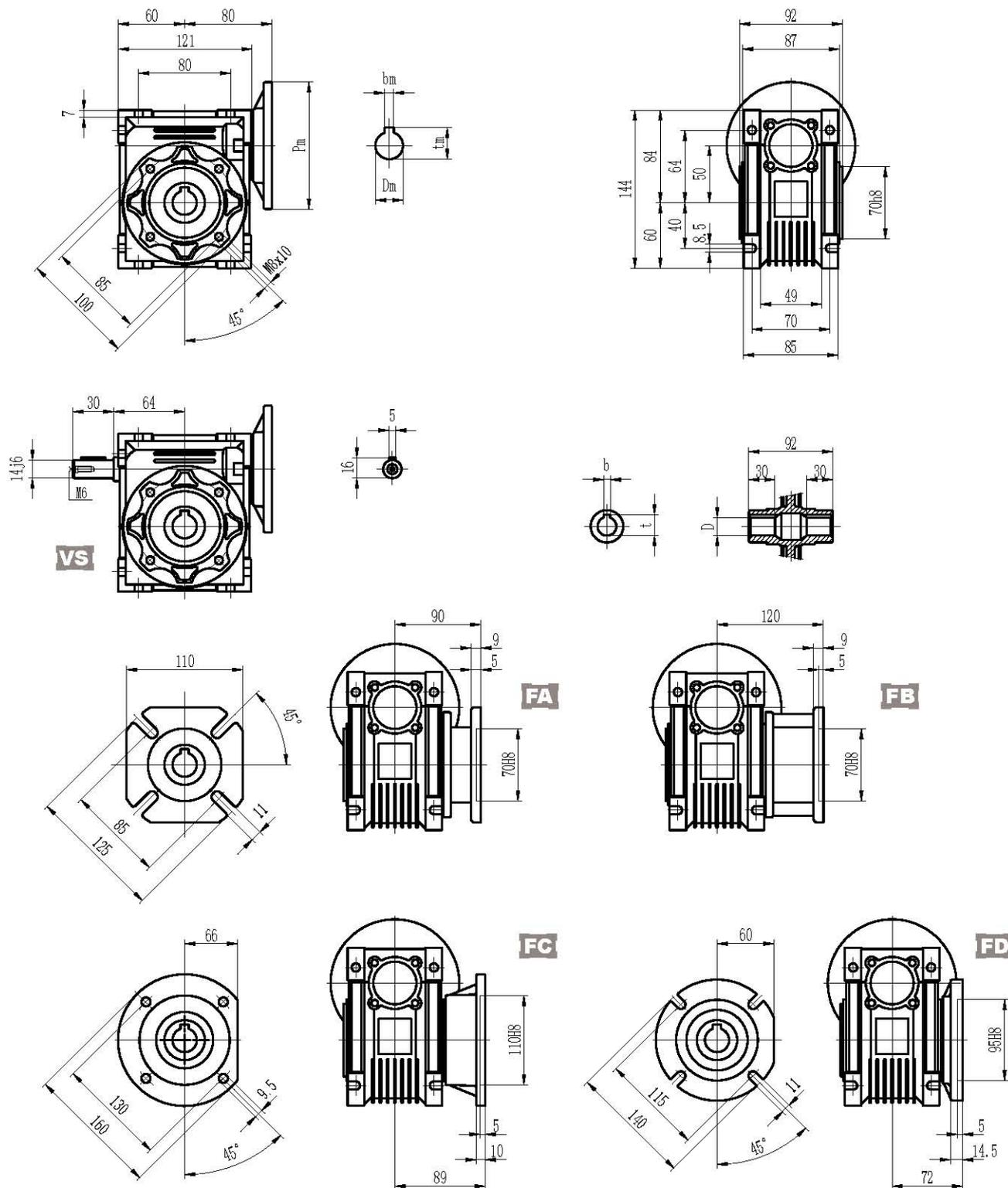

输出/Output		
D H8	b	t
25	8	28.3
(24)	(8)	(27.3)

(..) 根据用户要求定制
 *不带电机重量为:3.5kg
 *输入尺寸 (P_m, D_m, b_m, t_m) 参照第52页图表
 (..) Only on request
 *Weight without motor:3.5kg
 *for the dimensions concerning the motor connection area(P_m, D_m, b_m, t_m) please refer to the table shown at page 52

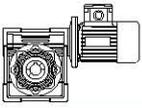

减速机外形尺寸 Dimensions

NMRV063

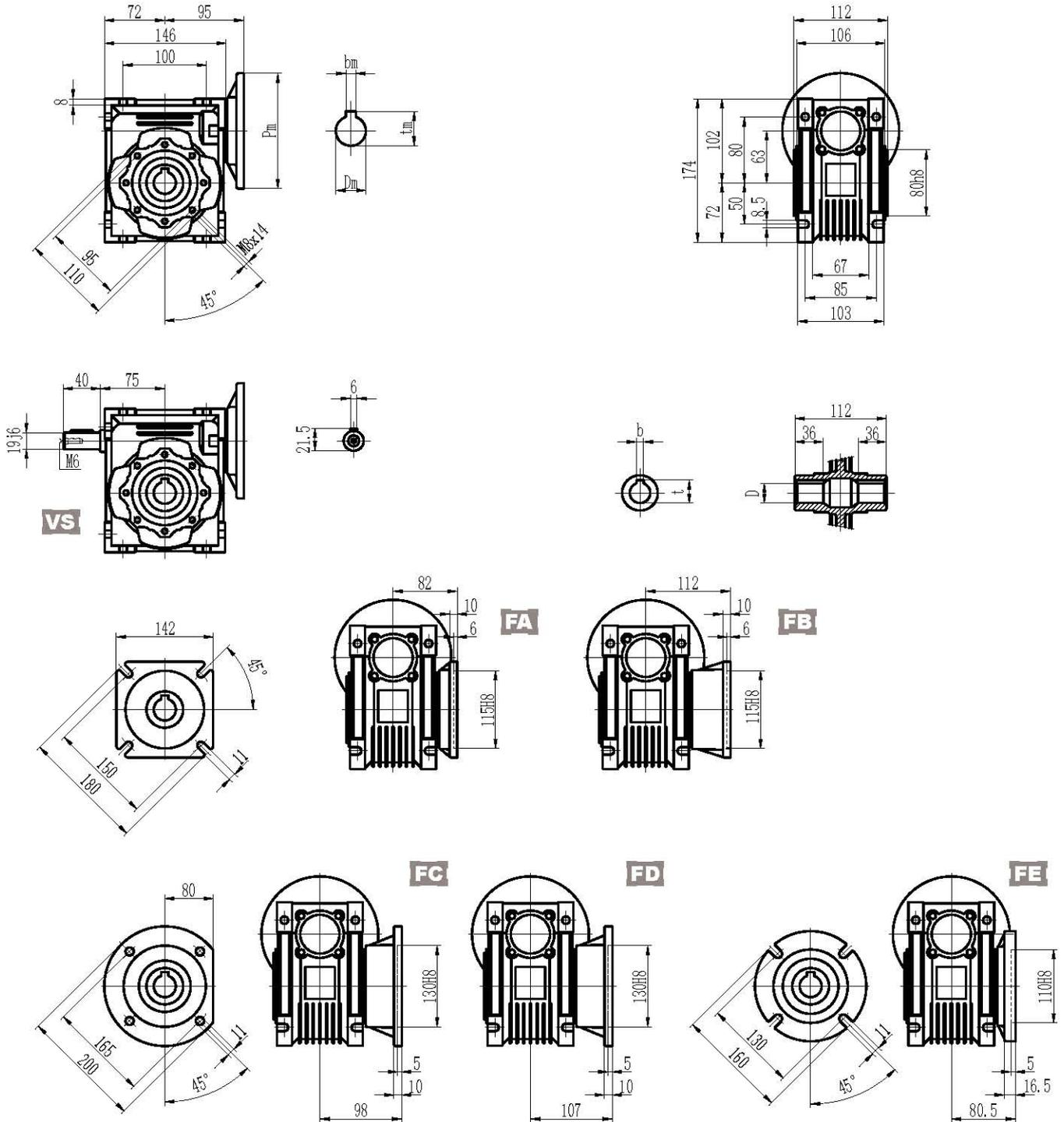

输出/Output		
D H8	b	t
25	8	28.3
(28)	(8)	(31.3)

(.) 根据用户要求定制
 *不带电机重量为:6.2kg
 *输入尺寸 (Pm, Dm, bm, tm) 参照第52页图表
 (.) Only on request
 *Weight without motor:6.2kg
 *for the dimensions concerning the motor connection area(Pm, Dm, bm, tm) please refer to the table shown at page 52

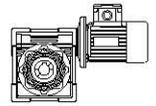

减速机外形尺寸 Dimensions

NMRV075

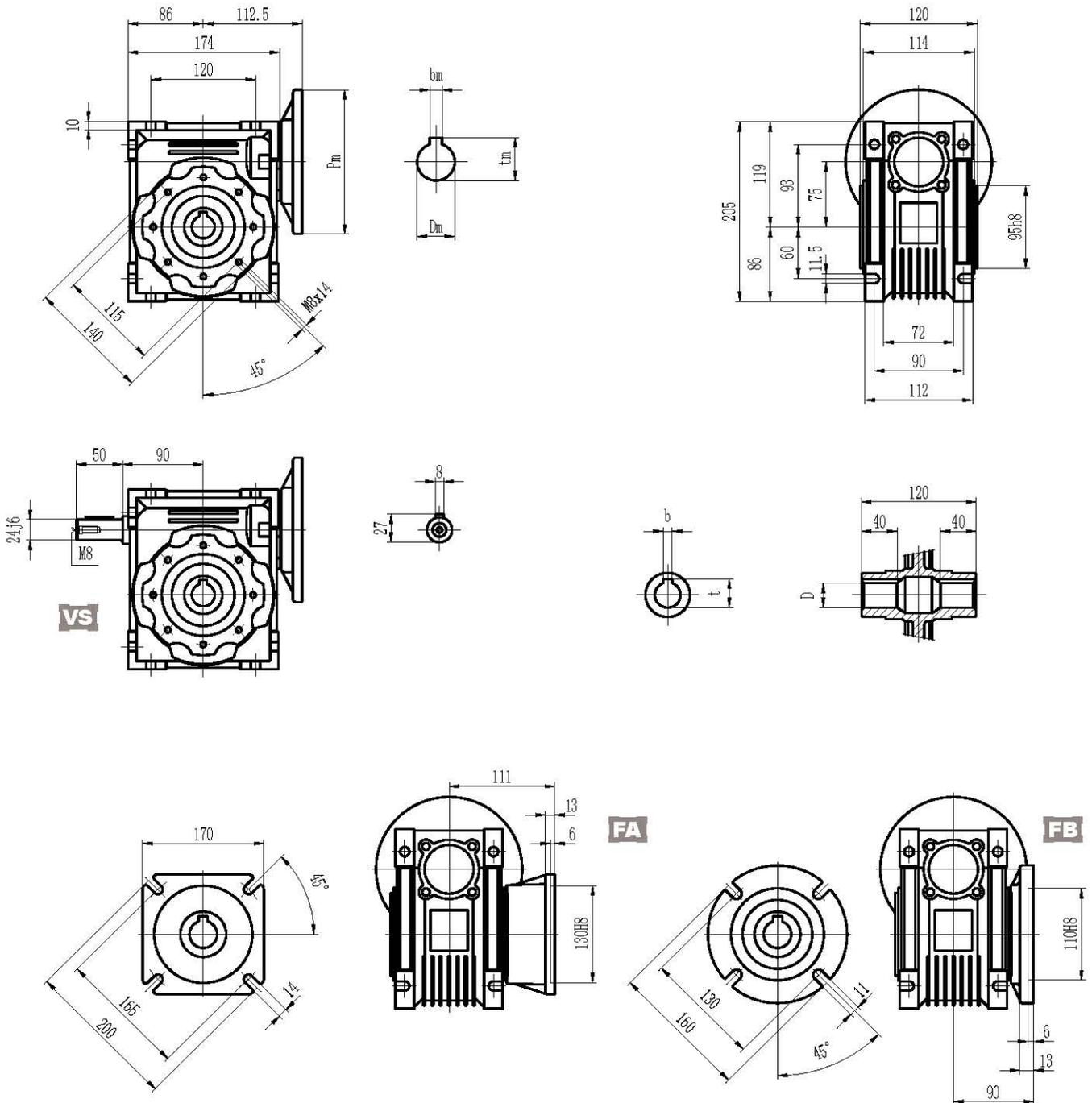

输出/Output		
D H8	b	t
28	8	31.3
(35)	(10)	(38.3)

(.) 根据用户要求定制
 *不带电机重量为:9kg
 *输入尺寸 (Pm, Dm, bm, tm) 参照第52页图表
 (.) Only on request
 *Weight without motor:9kg
 *for the dimensions concerning the motor connection area(Pm, Dm, bm, tm) please refer to the table shown at page 52

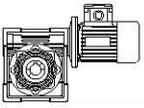

减速机外形尺寸 Dimensions

NMRV090

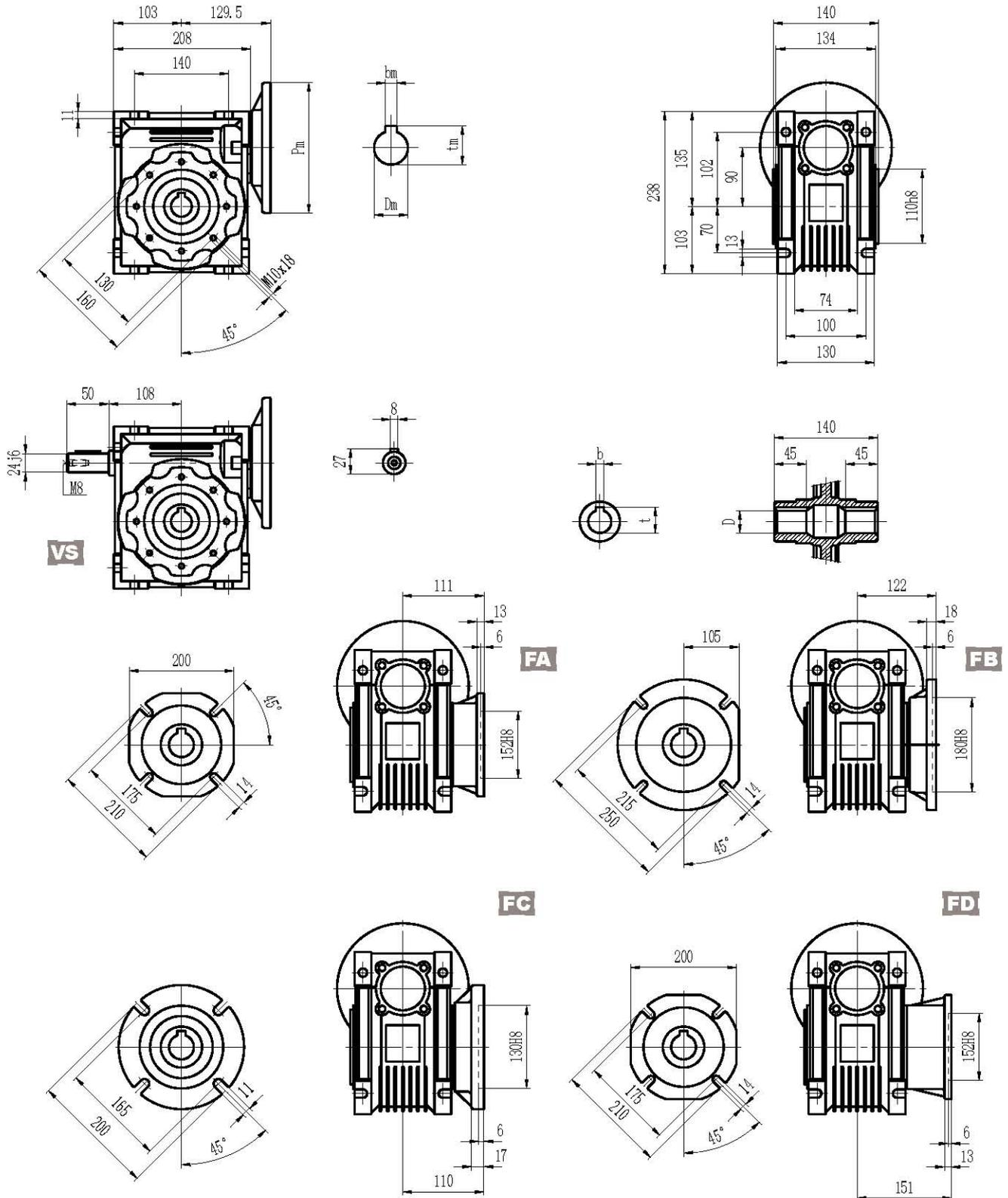

输出/Output		
D H8	b	t
35 (38)	10 (10)	38.3 (41.3)

(..) 根据用户要求定制
 *不带电机重量为:13kg
 *输入尺寸 (Pm, Dm, bm, tm) 参照第52页图表
 (..) Only on request
 *Weight without motor:13kg
 *for the dimensions concerning the motor connection area(Pm, Dm, bm, tm) please refer to the table shown at page 52

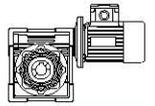

减速机外形尺寸 Dimensions

NMRV110

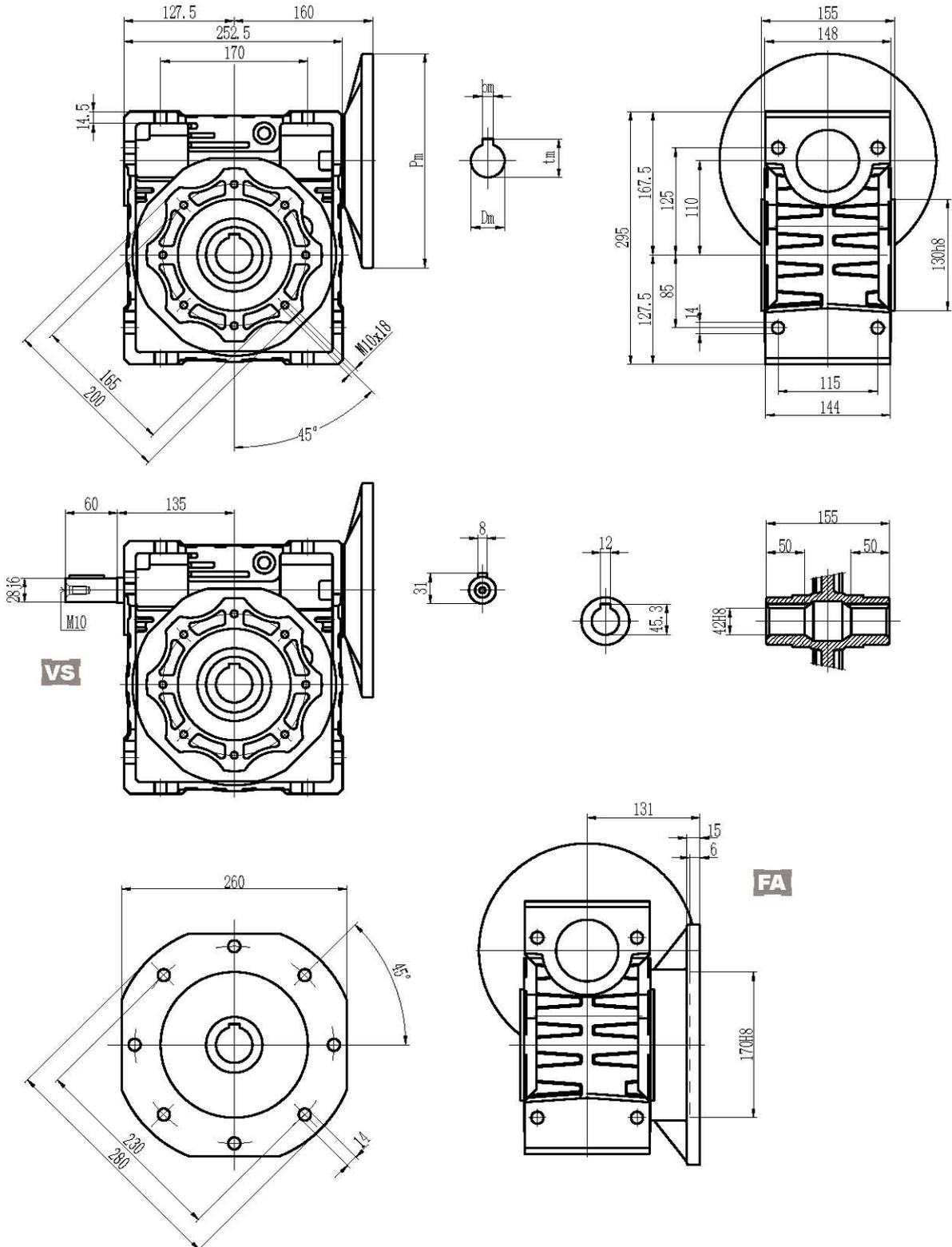

*不带电机重量为:35kg

*输入尺寸 (Pm, Dm, bm, tm) 参照第52页图表

*Weight without motor:35kg

*for the dimensions concerning the motor connection area(Pm,Dm,bm,tm)please refer to the table shown at page 52

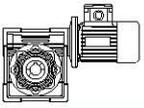

减速机外形尺寸 Dimensions

NMRV130

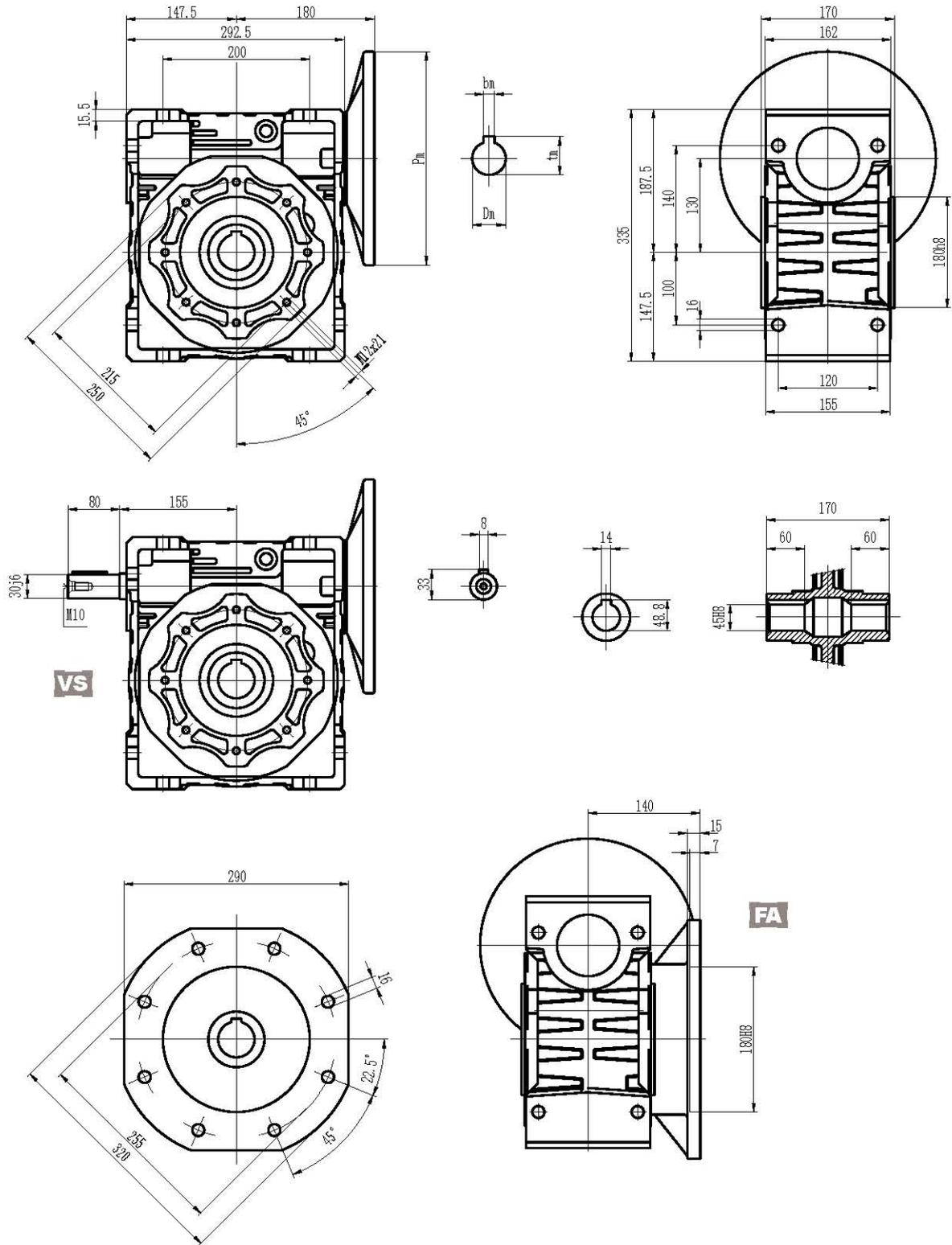

*不带电机重量为:48kg

*输入尺寸 (Pm, Dm, bm, tm) 参照第52页图表

*Weight without motor:48kg

*for the dimensions concerning the motor connection area(Pm, Dm, bm, tm) please refer to the table shown at page 52

NRV外形尺寸 NRV Dimensions

NRV

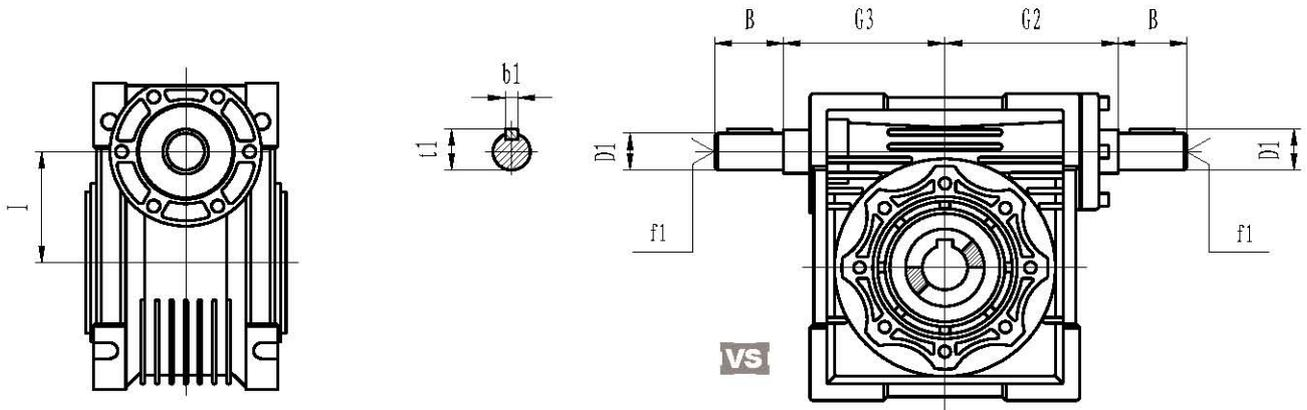

NRV	025	030	040	050	063	075	090	110	130
B	20	20	23	30	40	50	50	60	80
D1	9 j6	9 j6	11 j6	14 j6	19 j6	24 j6	24 j6	28 j6	30 j6
G2	38	51	60	74	90	105	125	142	162
G3	37	45	53	64	75	90	108	135	155
I	25	30	40	50	63	75	90	110	130
b1	3	3	4	5	6	8	8	8	8
f1	-	-	-	M6	M6	M8	M8	M10	M10
t1	10.2	10.2	12.5	16	21.5	27	27	31	33

低速轴 Low speed shafts

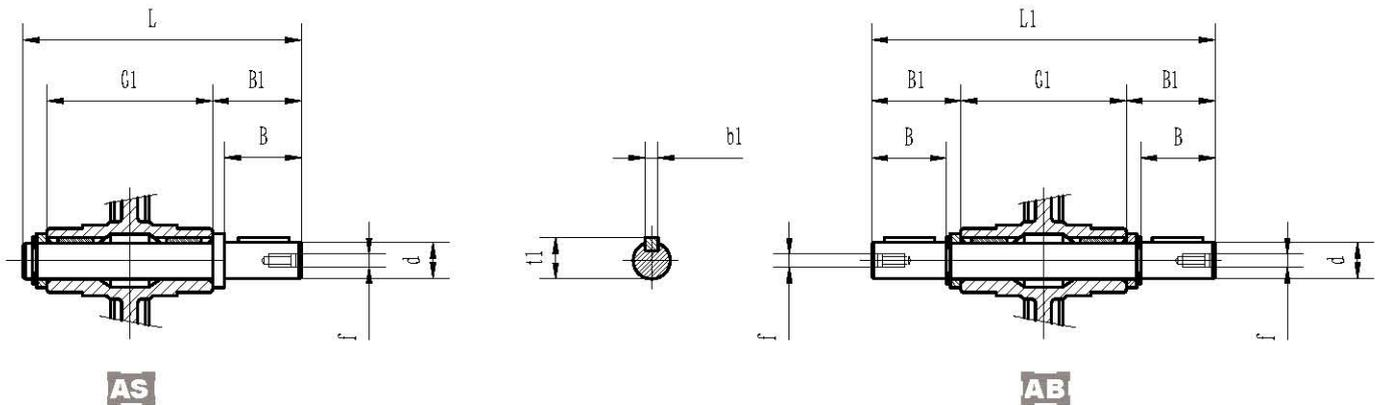

	d	B	B1	G1	L	L1	f	b1	t1
025	11g6 (9)	23 (25)	25.5 (30)	50	81 (85.5)	101	-	4 (3)	12.5 (10.2)
030	14g6	30	32.5	63	102	128	M6	5	16
040	18h6	40	43	78	128	164	M6	6	20.5
050	25h6	50	53.5	92	153	199	M10	8	28
063	25h6	50	53.5	112	173	219	M10	8	28
075	28h6	60	63.5	120	192	247	M10	8	31
090	35h6	80	84.5	140	234	309	M12	10	38
110	42h6	80	84.5	155	249	324	M16	12	45
130	45h6	80	85	170	265	340	M16	14	48.5

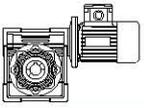

外罩 Cover

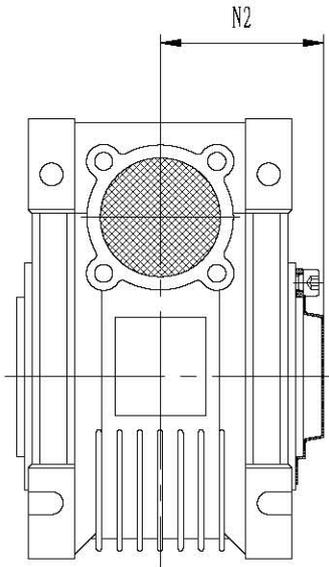

	N2
030	42
040	50
050	58
063	69
075	74
090	86
110	94
130	102

扭力臂 Torque arm

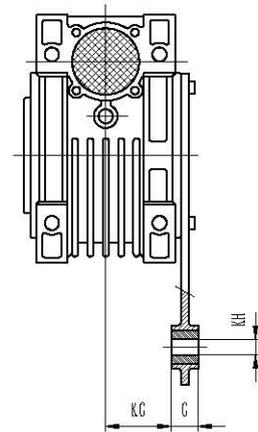
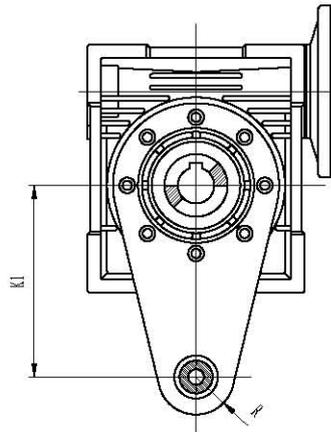

	K1	G	KG	KH	R
025	70	14	17.5	8	15
030	85	14	24	8	15
040	100	14	31.5	10	18
050	100	14	38.5	10	18
063	150	14	49	10	18
075	200	25	47.5	20	30
090	200	25	57.5	20	30
110	250	30	62	25	35
130	250	30	69	25	35

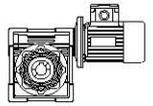

NMRV英制系列 Inch series

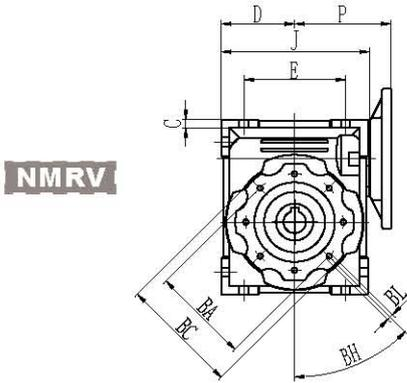

NMRV

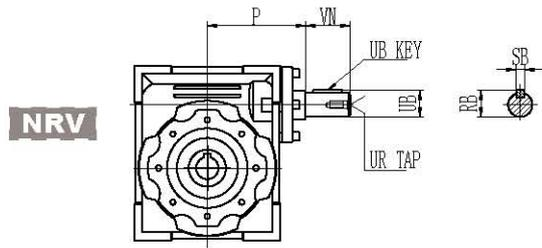

NRV

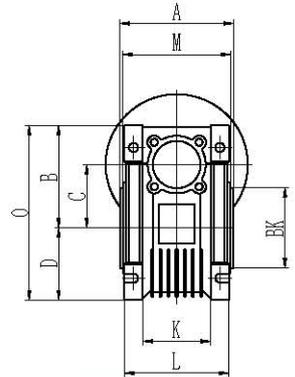

Shaft Mount

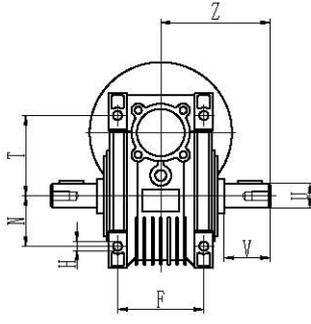

Foot Mount

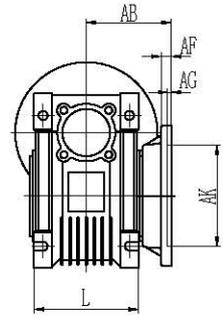

Flange Mount

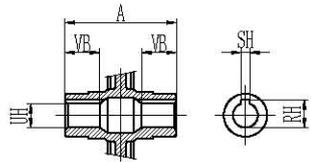

Hollow Output Bore

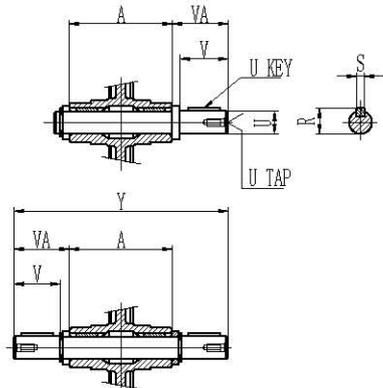

Output Shaft

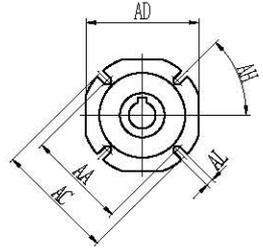

Output Flange

Hollow Output	030	040	050	063	075	090	110	130
RH	0.71	0.84	1.12	1.24	1.37	1.52	1.8	1.93
SH	0.188	0.188	0.25	0.25	0.25	0.313	0.375	0.375
UH	0.625 ^{+0.001} ₀	0.75 ^{+0.001} ₀	1 ^{+0.001} ₀	1.125 ^{+0.001} ₀	1.25 ^{+0.001} ₀	1.375 ^{+0.001} ₀	1.625 ^{+0.001} ₀	1.75 ^{+0.001} ₀
VB	0.83	1.14	1.28	1.42	1.56	1.77	1.97	2.24

Output Shaft	030	040	050	063	075	090	110	130
R	0.7	0.83	1.11	1.23	1.36	1.51	1.79	1.92
S	0.188	0.188	0.25	0.25	0.25	0.313	0.375	0.375
U	0.625 ⁰ _{-0.0005}	0.75 ⁰ _{-0.0005}	1 ⁰ _{-0.0005}	1.125 ⁰ _{-0.0005}	1.25 ⁰ _{-0.0005}	1.375 ⁰ _{-0.0005}	1.625 ⁰ _{-0.0005}	1.75 ⁰ _{-0.0005}
U KEY	0.1875x1.125	0.1875x1.5	0.25x1.5	0.25x1.875	0.25x2.25	0.3125x2.5	0.375x2.75	0.375x2.75
UT	1/4-20	1/4-20	3/8-16	3/8-16	1/2-13	1/2-13	5/8-11	5/8-11
V	1.57	1.97	1.97	2.36	2.76	3.15	3.54	3.54
VA	1.67	2.09	2.11	2.5	2.89	3.33	3.72	3.74
Y	5.82	7.25	7.84	9.41	10.5	12.17	13.54	14.17

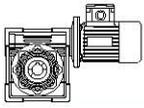

NMRV英制系列 Inch series

	030	040	050	063	075	090	110	130
A	2.48	3.07	3.62	4.41	4.72	5.51	6.1	6.69
B	2.24	2.81	3.31	4.02	4.69	5.31	6.59	7.38
BA	2.56	2.95	3.35	3.74	4.53	5.12	6.5	8.46
BC	2.95	3.43	3.94	4.33	5.51	6.3	7.87	9.84
BH	90°	45°	45°	45°	45°	45°	45°	45°
BK	2.165 ⁰ _{-0.0018}	2.362 ⁰ _{-0.0018}	2.756 ⁰ _{-0.0018}	3.15 ⁰ _{-0.0021}	3.74 ⁰ _{-0.0021}	4.331 ⁰ _{-0.0021}	5.118 ⁰ _{-0.0025}	7.087 ⁰ _{-0.0025}
BL	M6x11	M6x10	M8x10	M8x14	M8x14	M10x18	M10x18	M12x21
C	1.18	1.57	1.97	2.48	2.95	3.54	4.33	5.12
D	1.57	1.97	2.36	2.83	3.39	4.06	5.02	5.81
E	2.13	2.76	3.15	3.94	4.72	5.51	6.69	7.87
F	1.73	2.36	2.76	3.35	3.54	3.94	4.53	4.72
G	0.22	0.26	0.28	0.31	0.39	0.43	0.57	0.61
H	0.26	0.26	0.33	0.33	0.45	0.51	0.55	0.63
J	3.15	3.98	4.76	5.75	6.85	8.19	9.94	11.52
K	1.26	1.69	1.93	2.64	2.83	2.91	-	-
L	2.2	2.8	3.35	4.06	4.41	5.12	5.67	6.1
M	2.28	2.87	3.43	4.17	4.49	5.28	5.83	6.38
N	1.06	1.38	1.57	1.97	2.36	2.76	3.35	3.94
O	3.82	4.78	5.67	6.85	8.07	9.37	11.61	13.19
P	2.64	3.15	3.54	4.13	4.96	5.63	6.81	7.6
Q	0.83	2.36	2.91	3.54	4.13	4.92	5.59	6.38
T	1.73	2.17	2.52	3.15	3.66	4.02	4.92	5.51
Z	2.91	3.63	3.92	4.71	5.25	6.09	6.77	7.09

Output Flange		AA	AB	AC	AD	AF	AG	AH	AK	AL
030	FA	2.68	2.15	3.15	2.76	0.24	0.16	45°	1.969 ^{+0.0015} ₀	0.26
	FB	2.95	2.64	4.33	3.74	0.28	0.16	45°	2.362 ^{+0.0018} ₀	0.35
040	FB	2.95	3.82	4.33	3.74	0.28	0.16	45°	2.362 ^{+0.0018} ₀	0.35
	FC	4.53	3.15	5.51	-	0.35	0.2	45°	3.74 ^{+0.0021} ₀	0.37
050	FD	3.94	2.28	4.72	-	0.47	0.2	45°	3.15 ^{+0.0018} ₀	0.35
	FA	3.35	3.54	4.92	4.33	0.35	0.2	45°	2.756 ^{+0.0018} ₀	0.43
	FB	3.35	4.72	4.92	4.33	0.35	0.2	45°	2.756 ^{+0.0018} ₀	0.43
	FC	5.12	3.5	6.3	-	0.39	0.2	45°	4.331 ^{+0.0021} ₀	0.37
063	FD	4.53	2.83	5.51	-	0.57	0.2	45°	3.543 ^{+0.0021} ₀	0.43
	FA	4.13	3.23	7.09	5.59	0.39	0.24	45°	4.528 ^{+0.0021} ₀	0.43
	FB	5.91	4.41	7.09	5.59	0.39	0.24	45°	4.528 ^{+0.0021} ₀	0.43
	FC	6.5	3.86	7.87	-	0.39	0.2	45°	5.118 ^{+0.0025} ₀	0.43
075	FD	6.5	4.21	7.87	-	0.39	0.2	45°	5.118 ^{+0.0025} ₀	0.43
	FE	5.12	3.17	6.3	-	0.65	0.2	45°	4.331 ^{+0.0021} ₀	0.43
	FA	6.5	4.37	7.87	6.69	0.51	0.24	45°	5.118 ^{+0.0025} ₀	0.55
	FB	5.12	3.54	6.3	-	0.51	0.24	45°	4.331 ^{+0.0021} ₀	0.55
090	FA	6.89	4.37	8.27	8.27	0.51	0.24	45°	5.984 ^{+0.0025} ₀	0.55
	FB	8.46	4.8	9.84	-	0.71	0.24	45°	7.087 ^{+0.0025} ₀	0.55
	FC	6.5	4.33	7.87	-	0.67	0.24	45°	5.118 ^{+0.0025} ₀	0.43
	FD	6.89	5.94	8.27	-	0.51	0.24	45°	5.984 ^{+0.0025} ₀	0.55
110	FA	9.06	5.16	11.02	10.24	0.59	0.24	45°	6.693 ^{+0.0025} ₀	0.55
	FB	9.06	7.09	11.02	10.24	0.59	0.24	45°	6.693 ^{+0.0025} ₀	0.55
130	FA	10.04	5.51	12.6	11.42	0.59	0.24	22.5°	7.087 ^{+0.0025} ₀	0.63

Input Flange	030	040	050	063	075	090	110	130
SB	0.094	0.125	0.188	0.188	0.188	0.188	0.25	0.25
RB	0.42	0.55	0.7	0.83	0.96	0.96	1.24	1.36
UB	0.375 ⁰ _{-0.0005}	0.5 ⁰ _{-0.0005}	0.625 ⁰ _{-0.0005}	0.75 ⁰ _{-0.0005}	0.875 ⁰ _{-0.0005}	0.875 ⁰ _{-0.0005}	1.125 ⁰ _{-0.0005}	1.25 ⁰ _{-0.0005}
UB KEY	0.094x0.875	0.125x0.875	0.1875x1.125	0.1875x1.5	0.1875x1.875	0.1875x1.875	0.25x2.25	0.25x2.5
UR	-	1/4-20	1/4-20	1/4-20	1/4-20	1/4-20	3/8-16	1/2-13
VN	1.18	1.18	1.58	1.97	2.36	2.36	2.76	3.15

NMRV英制系列 Inch series

High Speed Extension Shaft

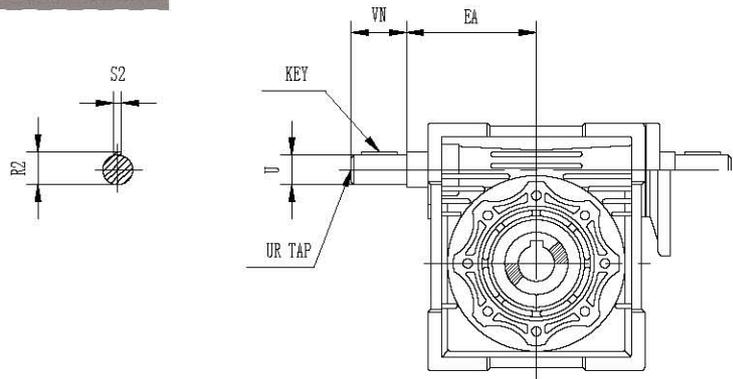

	EA	U	VN	UR	S2	R2	KEY	
							Length	Square
030	1.772	0.375 ⁰ _{-0.0005}	1.18	-	0.093	0.42	0.875	0.094
040	2.087	0.5 ⁰ _{-0.0005}	1.18	1/4-20	0.13	0.55	0.875	0.125
050	2.52	0.625 ⁰ _{-0.0005}	1.58	1/4-20	0.19	0.7	1.125	0.188
063	2.953	0.75 ⁰ _{-0.0005}	1.97	1/4-20	0.19	0.83	1.5	0.188
075	3.543	0.875 ⁰ _{-0.0005}	2.36	1/4-20	0.19	0.96	1.875	0.188
090	4.252	0.875 ⁰ _{-0.0005}	2.36	1/4-20	0.19	0.96	1.875	0.188
110	5.315	1.125 ⁰ _{-0.0005}	2.76	3/8-16	0.25	1.24	2.25	0.25
130	6.102	1.25 ⁰ _{-0.0005}	3.15	1/2-13	0.25	1.36	2.5	0.25

Torque Arm

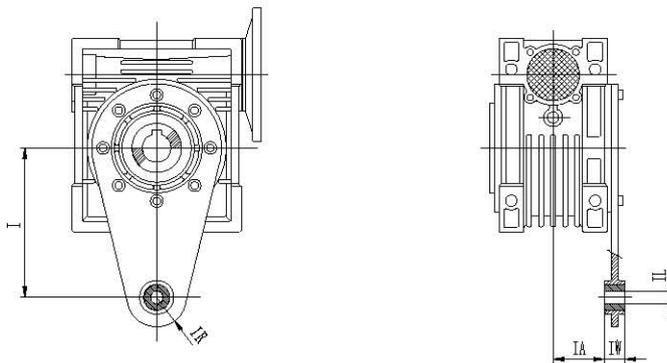

Protective Cover

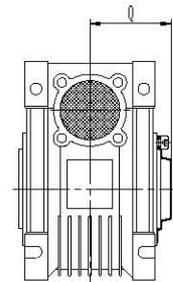

	I	IA	IL	IR	IW
025	2.76	0.69	0.31	0.59	0.55
030	3.35	0.94	0.31	0.59	0.55
040	3.94	1.24	0.39	0.71	0.55
050	3.94	1.52	0.39	0.71	0.55
063	5.91	1.93	0.39	0.71	0.55
075	7.87	1.87	0.79	1.18	0.98
090	7.87	2.26	0.79	1.18	0.98
110	9.84	2.44	0.98	1.38	1.18
130	9.84	2.72	0.98	1.38	1.18

	Q
030	1.65
040	1.97
050	2.28
063	2.72
075	2.91
090	3.39
110	3.7
130	4.02

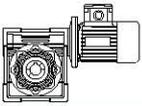

NEMA Flange Availability

	NEMA Flange	Input Bore Diameter	Available Ratios											
			5	7.5	10	15	20	25	30	40	50	60	80	100
030	48C	0.5	●	●	●	●	●	●	●	●	●	●	●	
040	56C	0.625	●	●	●	●	●	●	●	●	●	●	●	●
050	56C	0.625	●	●	●	●	●	●	●	●	●	●	●	●
063	56C	0.625					●	●	●	●	●	●	●	●
	140TC	0.875		●	●	●	●	●	●	●				
075	56C	0.625									●	●	●	●
	140TC	0.875				●	●	●	●	●	●			
	180TC	1.125		●	●	●								
090	56C	0.625											●	●
	140TC	0.875						●	●	●	●	●		
	180TC	1.125		●	●	●	●	●	●	●				
110	140TC	0.875									●	●	●	●
	180TC	1.125					●	●	●	●	●	●		
	210TC	1.375		●	●	●	●							
130	140TC	0.875											●	●
	180TC	1.125							●	●	●	●	●	
	210TC	1.375		●	●	●	●	●	●	●				

PC-NMRV

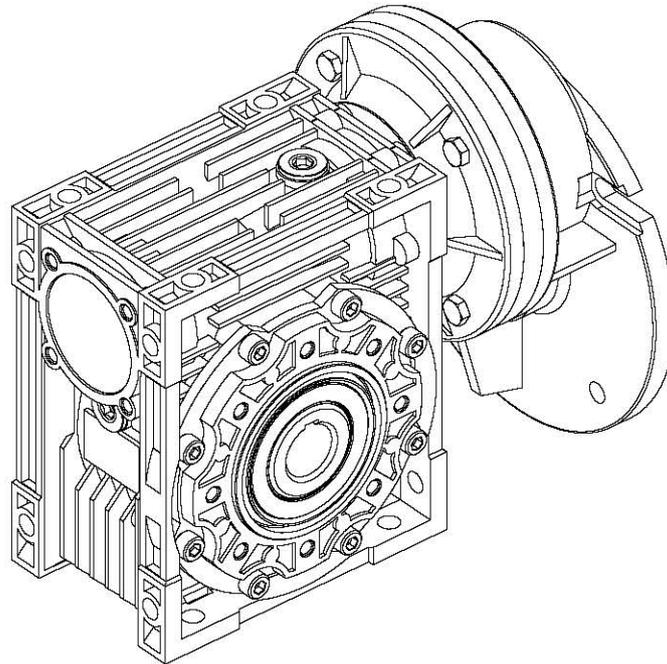

PC-NMRV型号标记 Model & marker

PC-071-NMRV-063-30-VS-F1(FA)-AS-80B5-0.75kW-B3			
PC	前置级减速模块 Pre-stage helical module		
071	尺寸 Size		
NMRV	蜗轮减速器 Worm geared motor		
063	蜗轮减速器中心距 Center dictance		
30	减速比 Reduction ratio		
VS	双向输入轴 Double input shaft	F1(FA)	输出法兰位置及型号 Output flange
AS	单向输出轴 Single output shaft	AB	双向输出轴 Double output shaft
PAM	电机联接 Fitted for motor coupling	80B5	电机机座号和安装结构形式 Motor mounting facility
0.75kW	电机功率 Electric motor power	B3	安装方位 Mounting position

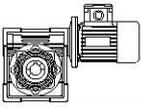

PC+NMRV组合方式 Combinations

NMRV	i	PC063		PC071		PC080			PC090		
		105/11	105/14	120/14	120/19	160/19	160/24	160/28	160/19	160/24	160/28
		2.93	i=2.93	i=2.94	i=2.94	i=3	i=3	i=3	i=2.45	i=2.45	i=2.45
040	25										
	30										
	40										
	50										
	60										
	80										
	100										
050	25										
	30										
	40										
	50										
	60										
	80										
	100										
063	25										
	30										
	40										
	50										
	60										
	80										
	100										
075	25										
	30										
	40										
	50										
	60										
	80										
	100										
090	25										
	30										
	40										
	50										
	60										
	80										
	100										
110	25										
	30										
	40										
	50										
	60										
	80										
	100										
130	25										
	30										
	40										
	50										
	60										
	80										
	100										

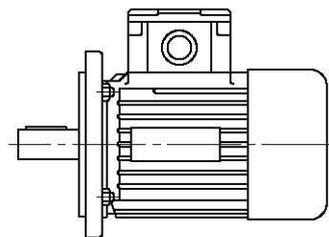
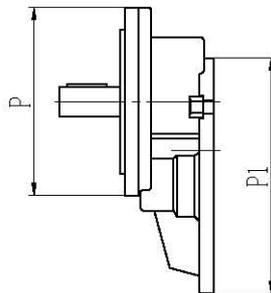
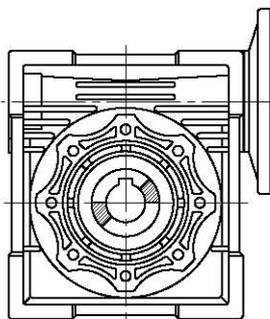

	P1	P	(P)
PC 063	63B5-140/11	105/11	(105/14)
PC 071	71B5-160/14	120/14	(120/19)
PC 080	80B5-200/19	160/19	(160/24)
			(160/28)
PC 090	90B5-200/24	160/24	(160/19)
			(160/28)

(..) 根据用户要求定制
 (..) Only on request

PC-NMRV安装方位 Mounting positions

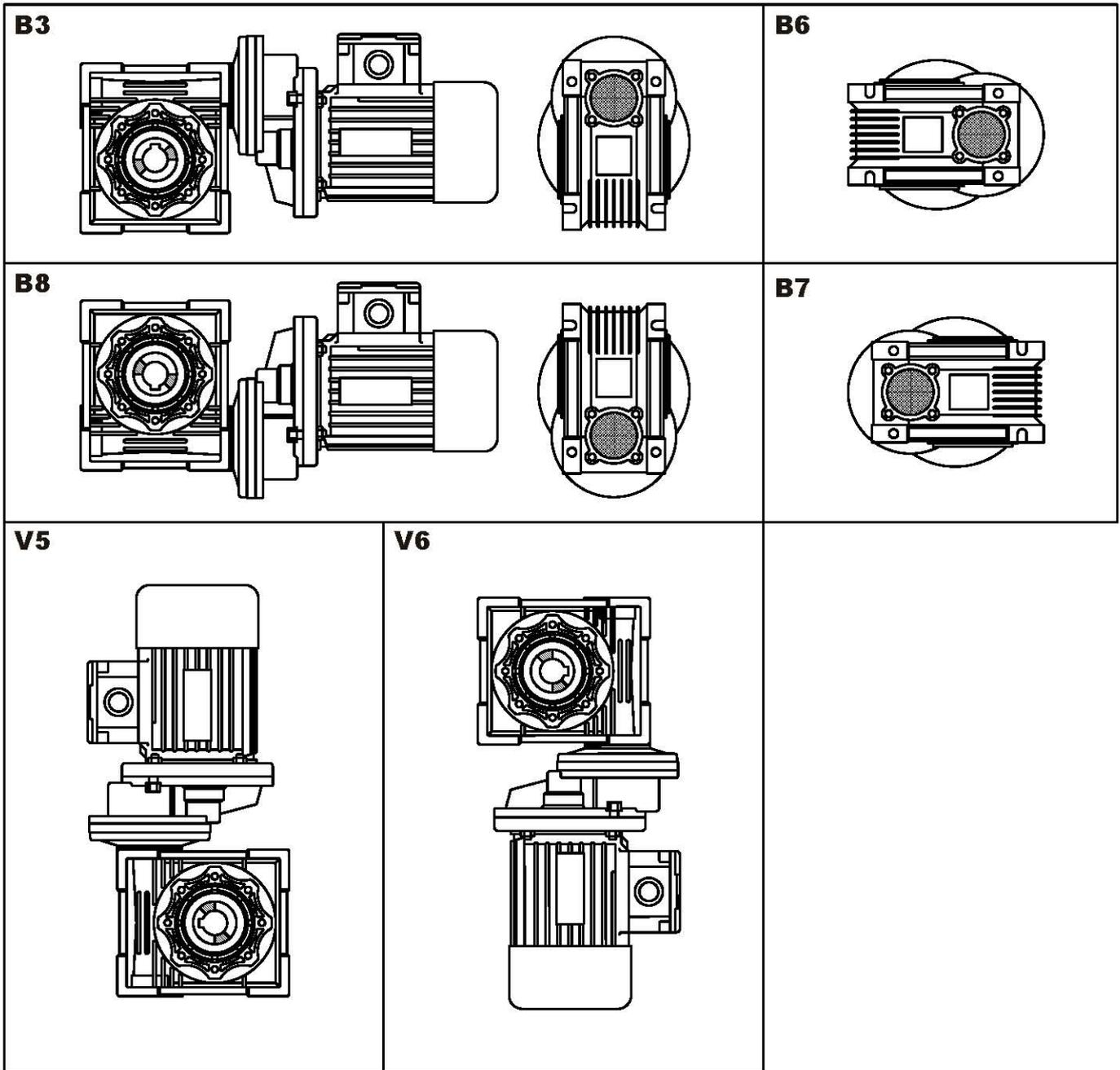

润滑油的选用 Choice of lubricant

油量公升数 Q. ty of oil in litres				合成油 Synthetic										
				ISO	VG32	VG320								
<table border="1"> <thead> <tr> <th>063</th> <th>071</th> <th>080</th> <th>090</th> </tr> </thead> <tbody> <tr> <td>0.16</td> <td>0.25</td> <td>0.28</td> <td>0.28</td> </tr> </tbody> </table>				063	071	080	090	0.16	0.25	0.28	0.28	国内使用 Used in interior	广研润滑	CKC150
				063	071	080	090							
0.16	0.25	0.28	0.28											
国外使用 Used in foreign Countries				IP	TELIUM VSF									
				SHELL	TIVELA OIL SC320									
				AGIP	BLASIA S320									
				MOBIL	GLYGOYLE 30									
				CASTROL	ALPHASYN PG 320									

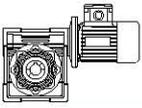

PC+NMRV外形尺寸 Dimensions

PC 063 - NMRV 040

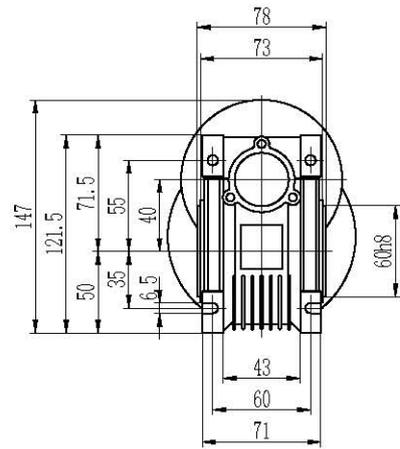
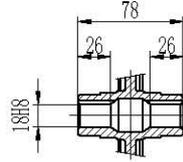
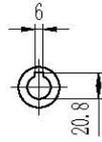
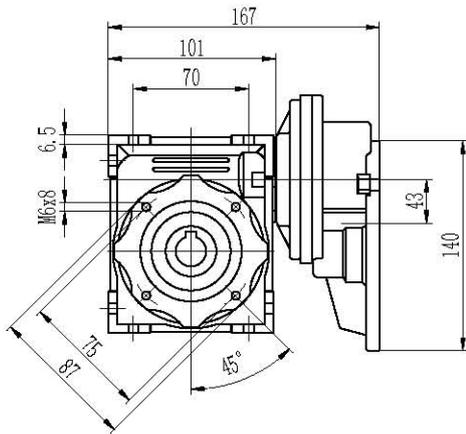

PC 063 - NMRV 050

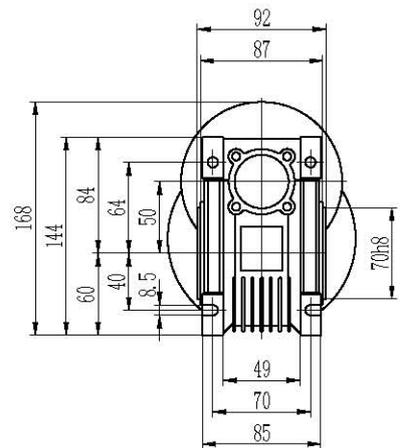
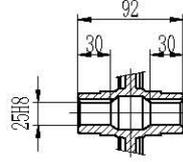
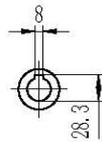
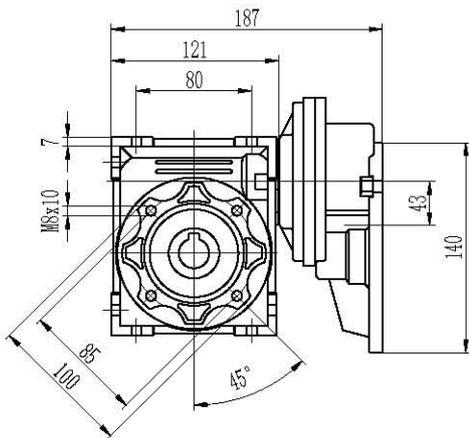

PC 063 - NMRV 063

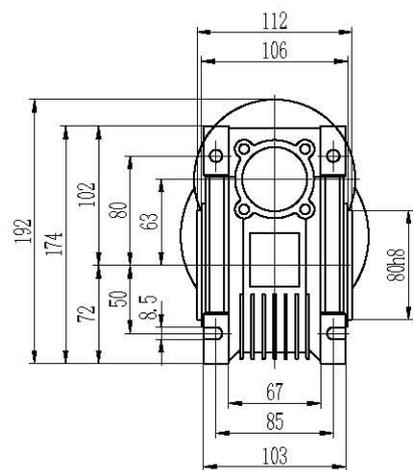
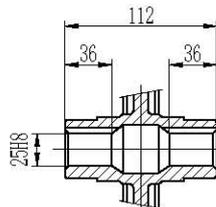
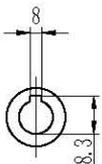
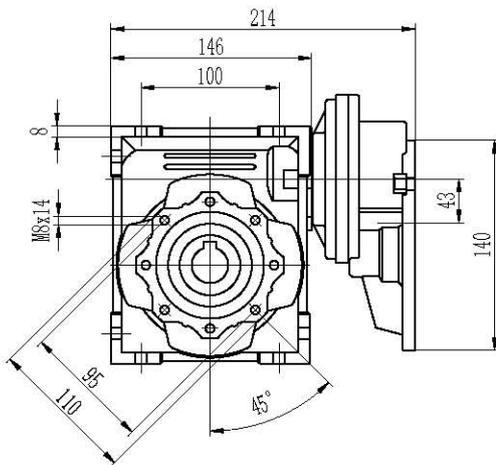

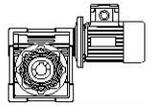

PC+NMRV外形尺寸 Dimensions

PC 071 - NMRV 050

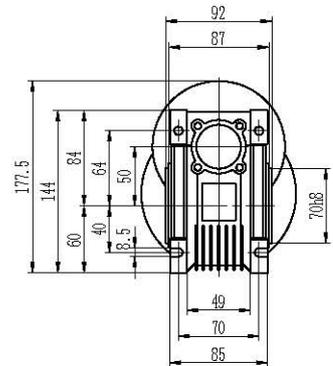
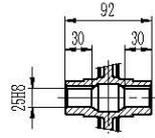
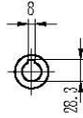
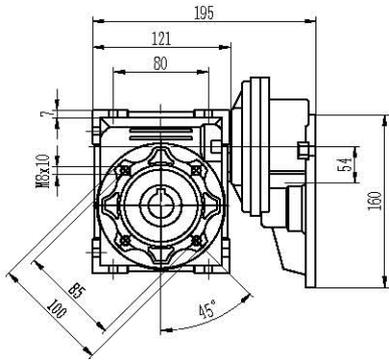

PC 071 - NMRV 063

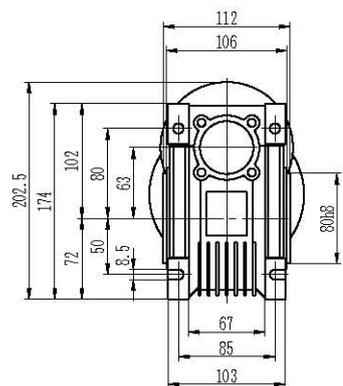
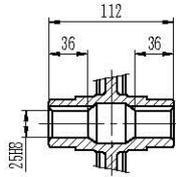
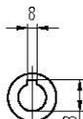
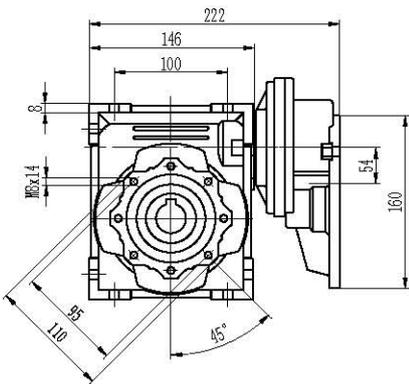

PC 071 - NMRV 075

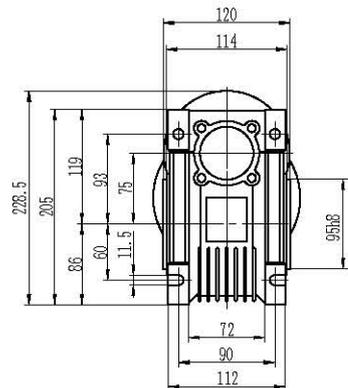
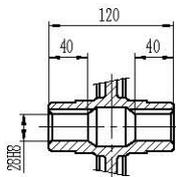
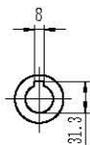
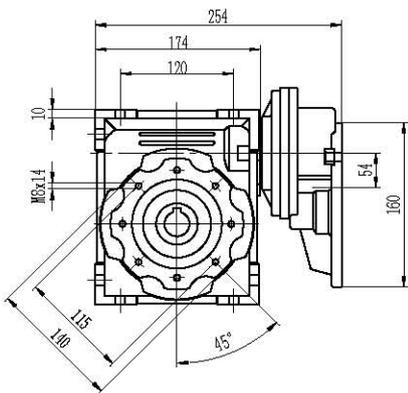

PC 071 - NMRV 090

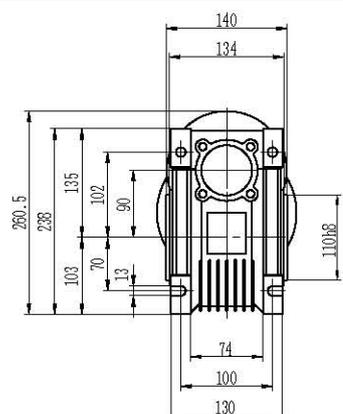
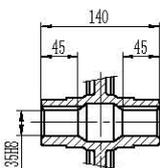
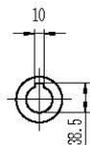
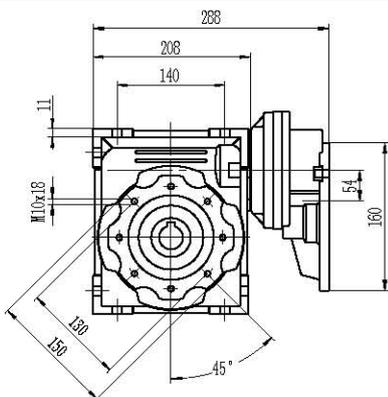

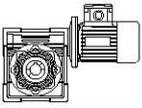

PC+NMRV外形尺寸 Dimensions

PC 080 - NMRV 075

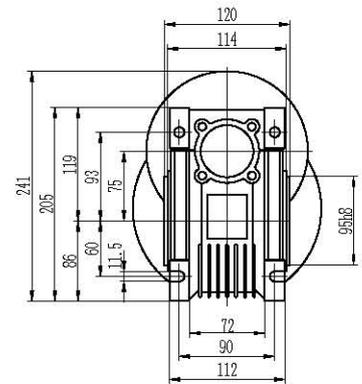
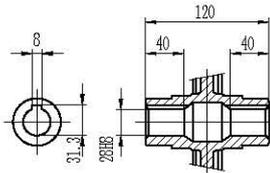
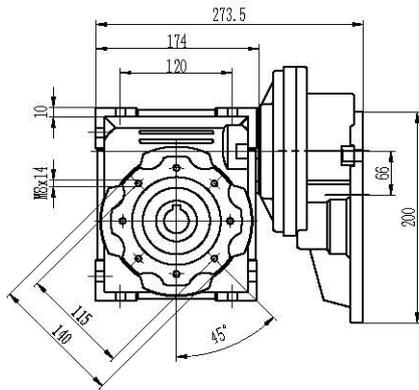

PC 080 - NMRV 090

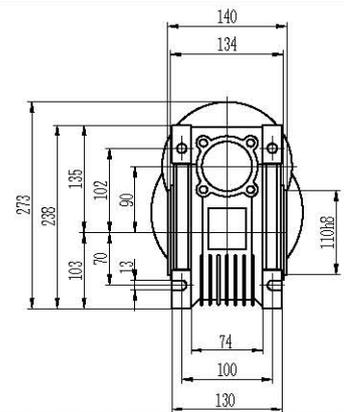
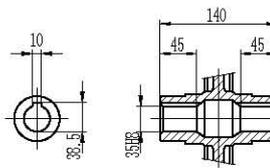
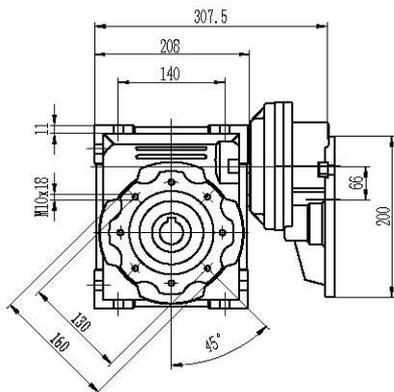

PC 080(090) - NMRV 110

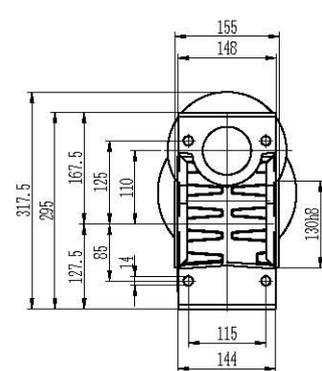
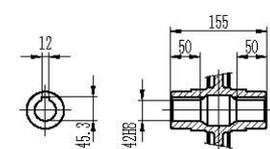
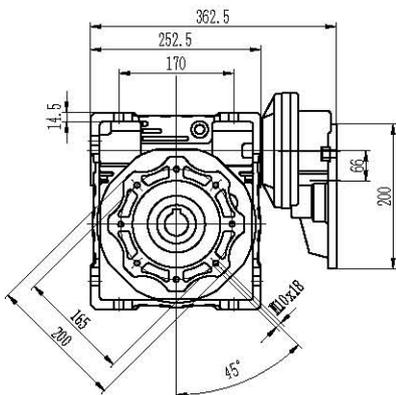

PC 080(090) - NMRV 130

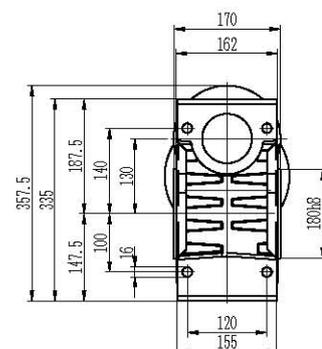
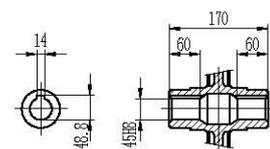
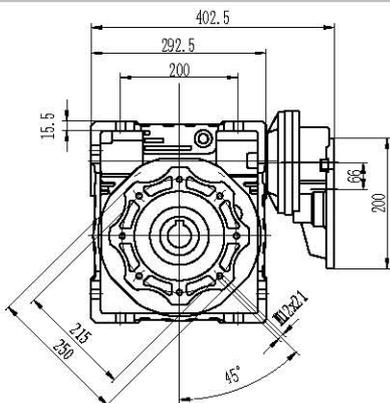

NMRV-NMRV

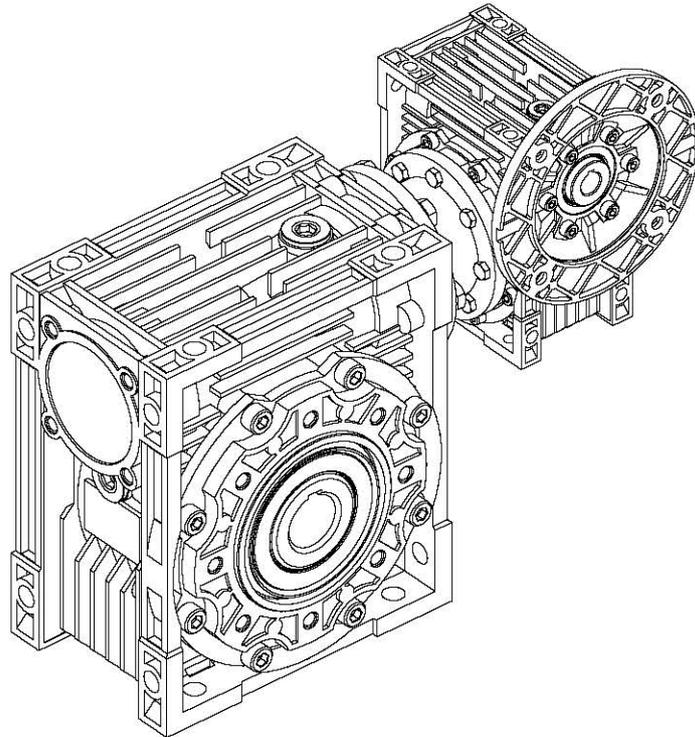

NMRV-NMRV型号标记 Model & marker

NMRV-040/090-500-VS-F1(FA)-AS-80B5-0.75kW-AS1

NMRV+NMRV	双蜗轮减速器 Combined worm geared motor		
NRV+NMRV	配输入轴双蜗轮减速器 Combined worm reduction unit		
040/090	蜗轮减速器中心距 Center distance		
500	减速比 Reduction ratio		
VS	双向输入轴 Double input shaft	F1(FA)	输出法兰位置及型号 Output flange
AS	单向输出轴 Single output shaft	AB	双向输出轴 Double output shaft
PAM	电机联接 Fitted for motor coupling	80B5	电机机座号和安装结构形式 Motor mounting facility
0.75kW	电机功率 Electric motor power	AS1	安装方位 Mounting position

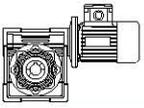

NMRV-NMRV 安装方位 Mounting positions

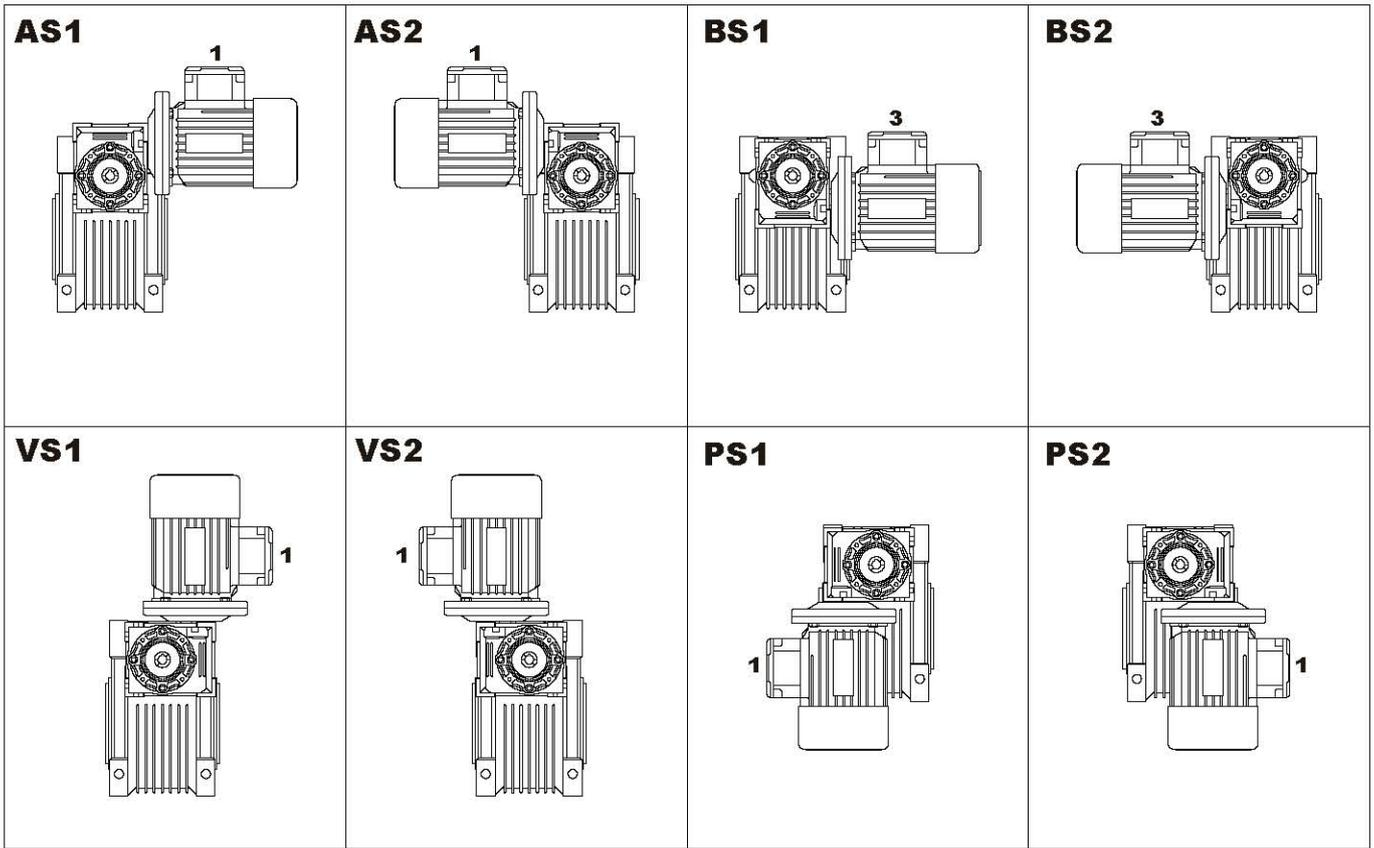

法兰位置 Flange F-FL

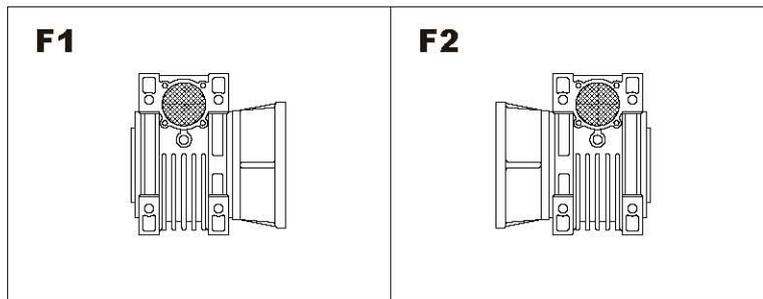

接线盒安装方式 Pos. of terminal box

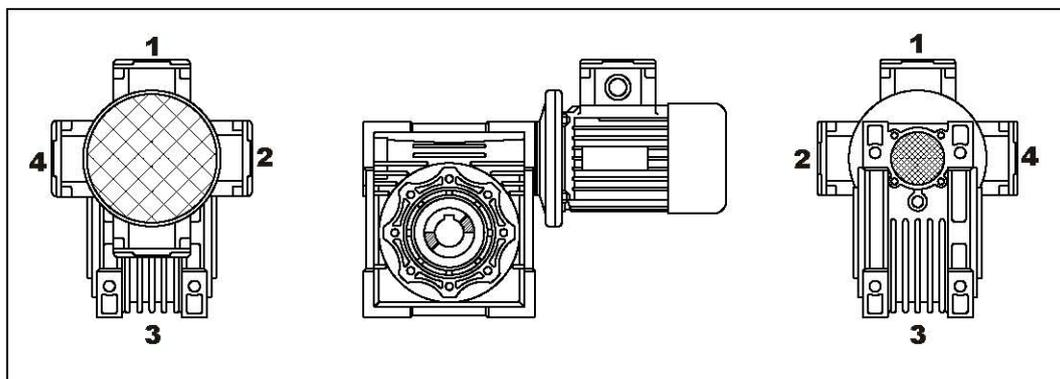

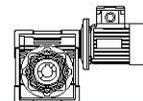

NMRV-NMRV参数表 Parameter table

*n1=1400rpm

	i	n2	kW1	M2 (Nm)	i1	i2		i	n2	kW1	M2 (Nm)	i1	i2
NRV 030/040	300	4.7	0.08	73	10	30	NRV 040/090	300	4.7	0.56	610	7.5	40
	400	3.5	0.06	65	10	40		400	3.5	0.43	610	10	40
	500	2.8	0.04	61	20	25		500	2.8	0.34	560	10	50
	600	2.3	0.04	73	20	30		600	2.3	0.3	610	15	40
	750	1.9	0.04	73	25	30		750	1.9	0.23	560	15	50
	900	1.6	0.03	73	30	30		900	1.6	0.19	505	15	60
	1200	1.2	0.02	65	30	40		1200	1.2	0.17	610	30	40
	1500	0.9	0.02	73	50	30		1500	0.93	0.14	560	30	50
	1800	0.8	0.02	73	60	30		1800	0.78	0.11	505	30	60
	2400	0.58	0.01	65	60	40		2400	0.58	0.11	610	60	40
	3200	0.4	0.01	65	80	40		3000	0.47	0.08	560	60	50
	4000	0.4	0.01	33	50	80		4000	0.35	0.08	460	50	80
5000	0.28	0.01	29	50	100	5000	0.28	0.06	410	50	100		
NRV 030/050	300	4.7	0.15	145	10	30	NRV 050/110	300	4.7	0.95	1100	10	30
	400	3.5	0.1	124	10	40		400	3.5	0.69	1030	10	40
	500	2.8	0.09	120	10	50		500	2.8	0.56	1000	10	50
	600	2.3	0.08	145	20	30		600	2.3	0.48	1030	15	40
	750	1.9	0.07	145	25	30		750	1.9	0.43	1100	25	30
	900	1.6	0.06	145	30	30		900	1.6	0.38	1100	30	30
	1200	1.2	0.04	124	30	40		1200	1.2	0.27	1030	30	40
	1500	0.93	0.04	145	50	30		1500	0.93	0.28	1100	50	30
	1800	0.78	0.04	145	60	30		1800	0.78	0.23	1100	60	30
	2400	0.6	0.03	124	60	40		2400	0.58	0.17	1030	60	40
	3000	0.5	0.02	120	60	50		3000	0.47	0.14	1000	60	50
	4000	0.35	0.02	82	50	80		4000	0.35	0.12	780	50	80
4800	0.29	0.02	82	60	80	5000	0.28	0.09	710	50	100		
NRV 030/063	300	4.7	0.24	230	7.5	40	NRV 063/130	300	4.7	1.48	1760	10	30
	400	3.5	0.19	230	10	40		400	3.5	1.09	1650	10	40
	500	2.8	0.15	216	10	50		500	2.8	0.86	1550	10	50
	600	2.3	0.13	230	15	40		600	2.3	0.76	1650	15	40
	750	1.9	0.11	216	15	50		750	1.9	0.66	1760	25	30
	900	1.6	0.09	198	15	60		900	1.6	0.58	1760	30	30
	1200	1.2	0.08	230	30	40		1200	1.2	0.43	1650	30	40
	1500	0.93	0.06	216	30	50		1500	0.93	0.39	1760	50	30
	1800	0.78	0.05	198	30	60		1800	0.78	0.35	1760	60	30
	2400	0.58	0.05	230	60	40		2400	0.58	0.25	1650	60	40
	3000	0.47	0.04	216	60	50		3000	0.47	0.2	1550	60	50
	4000	0.35	0.03	172	50	80		4000	0.35	0.15	1220	50	80
5000	0.28	0.02	150	50	100	5000	0.28	0.11	1100	50	100		
NRV 040/075	300	4.7	0.36	390	10	30	..						
	400	3.5	0.27	360	10	40							
	500	2.8	0.21	320	10	50							
	600	2.3	0.19	390	20	30							
	750	1.9	0.16	390	25	30							
	900	1.6	0.14	390	30	30							
	1200	1.2	0.11	360	30	40							
	1500	0.93	0.1	390	50	30							
	1800	0.78	0.09	390	60	30							
	2400	0.58	0.07	360	60	40							
	3000	0.47	0.05	320	60	50							
	4000	0.35	0.04	250	50	80							
5000	0.28	0.03	230	50	100								

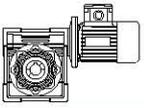

NMRV-NMRV外形尺寸 Dimensions

NMRV 025 - NMRV 030

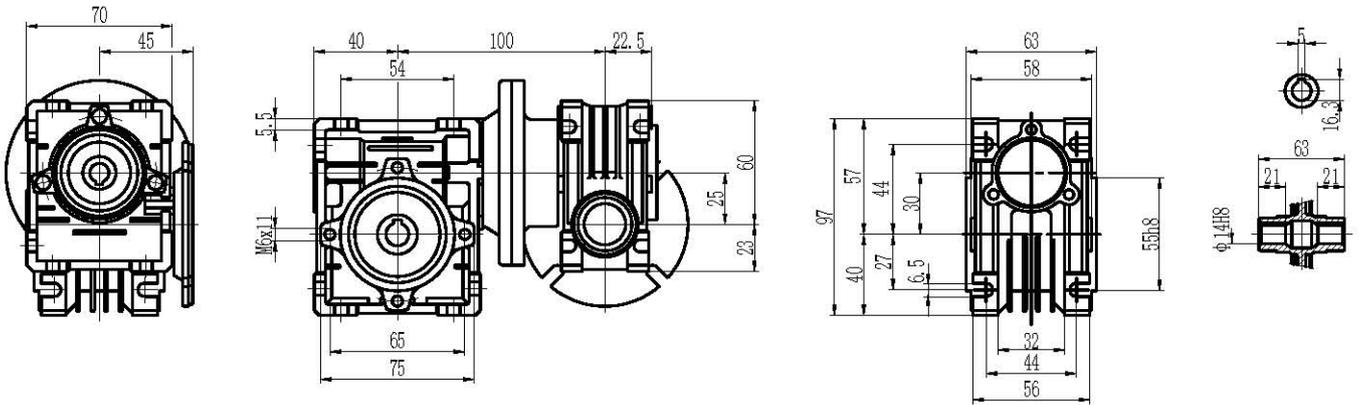

NMRV 025 - NMRV 040

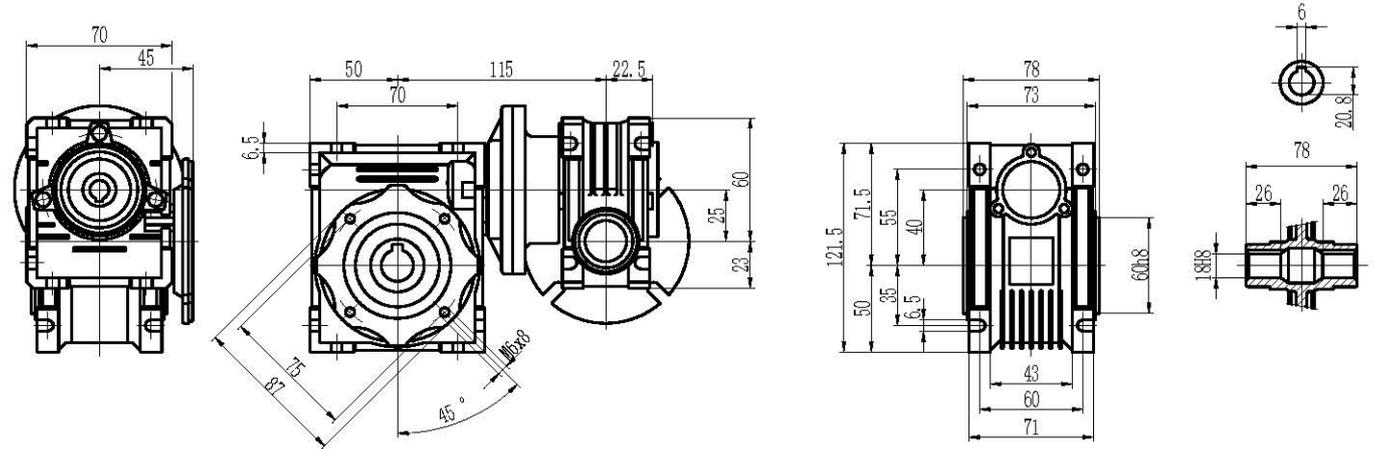

NMRV 030 - NMRV 040

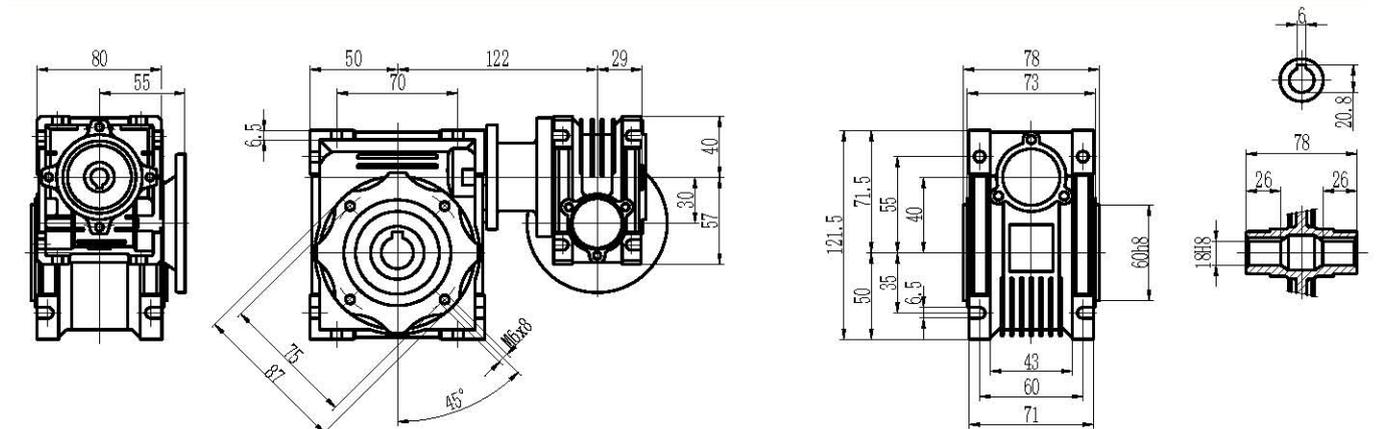

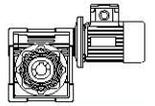

NMRV-NMRV外形尺寸 Dimensions

NMRV 030 - NMRV 050

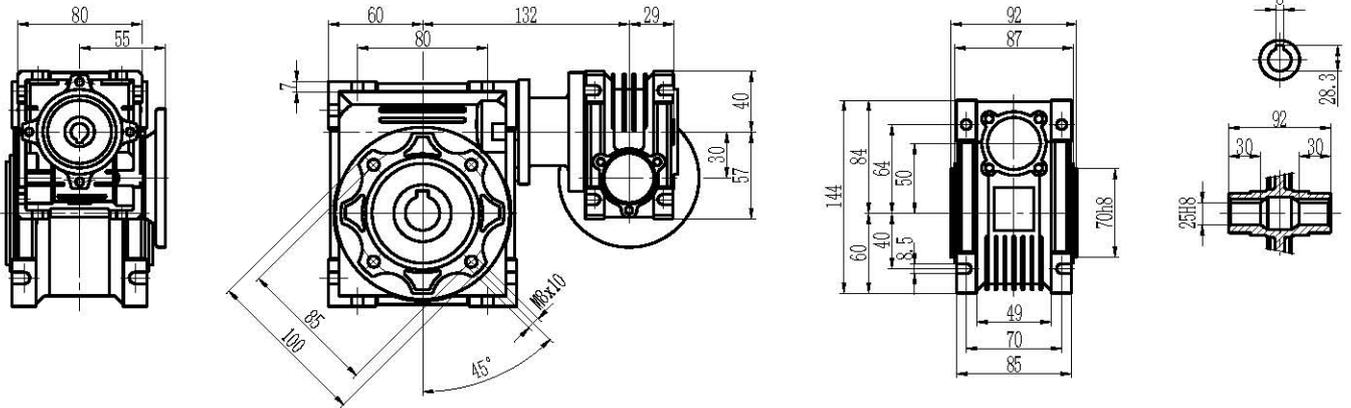

NMRV 030 - NMRV 063

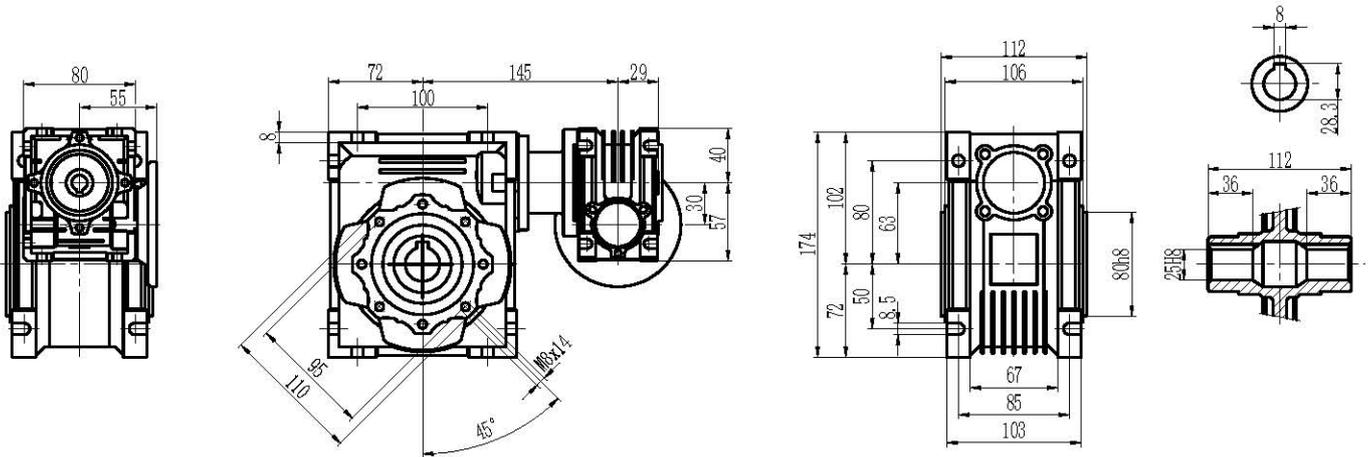

NMRV 040 - NMRV 075

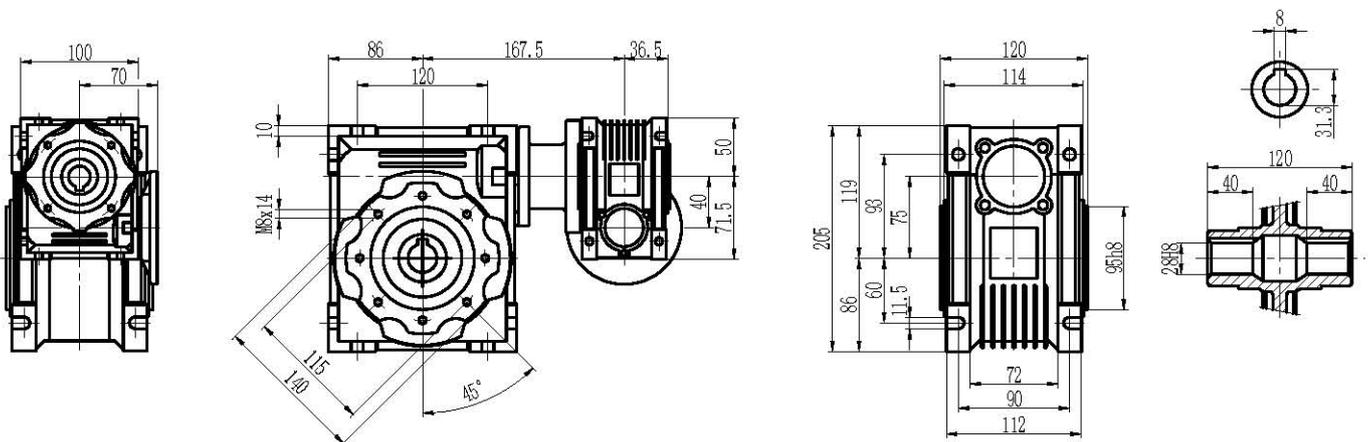

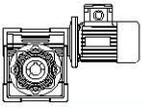

NMRV-NMRV外形尺寸 Dimensions

NMRV 040 - NMRV 090

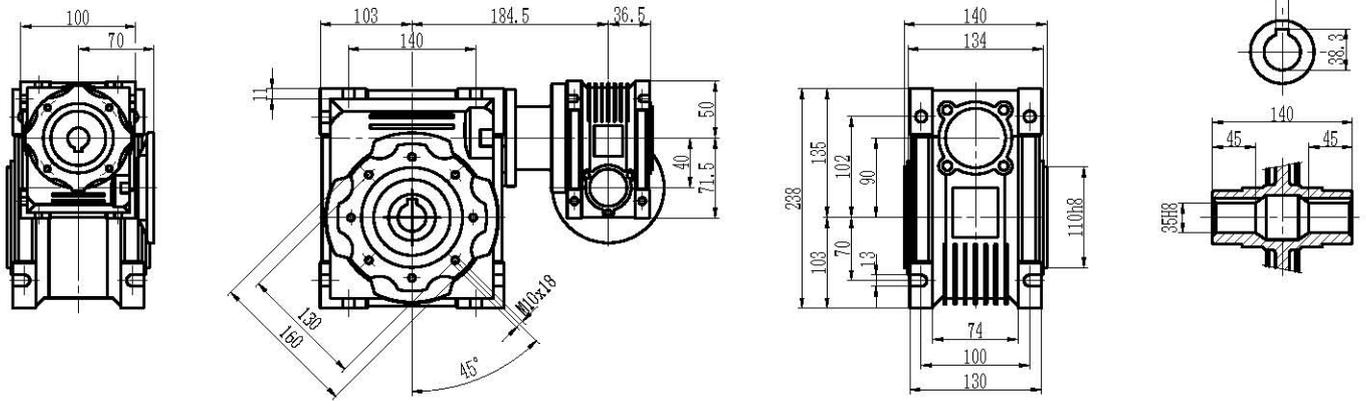

NMRV 050 - NMRV 110

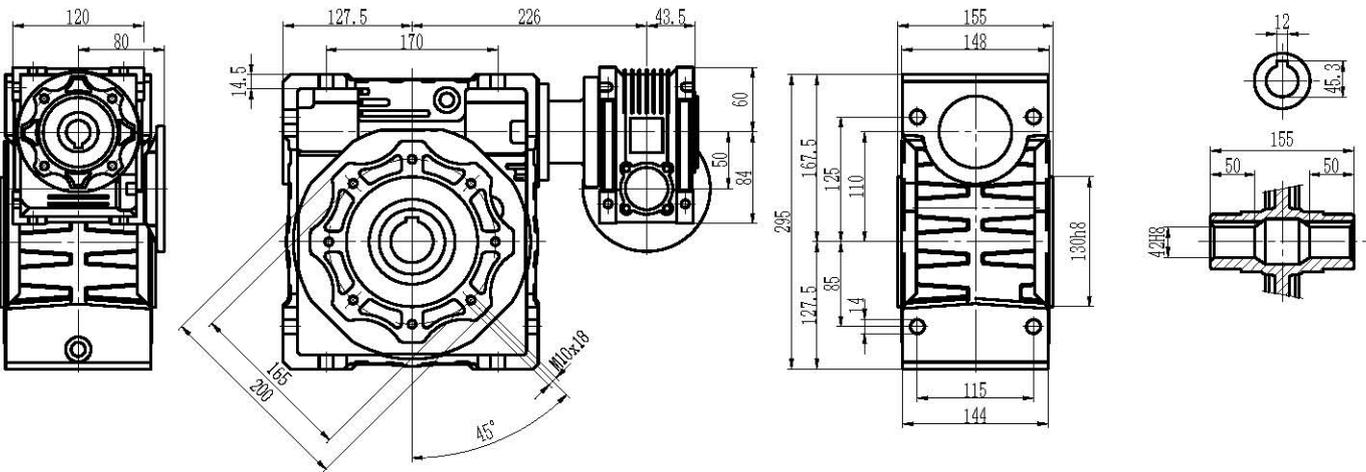

NMRV 063 - NMRV 130

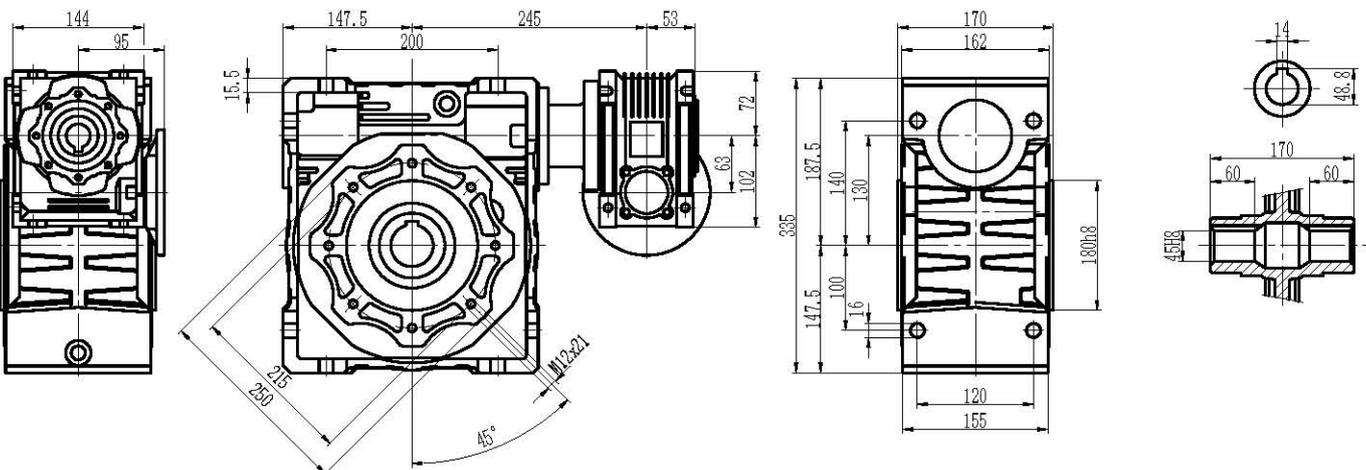

NRV-NMRV外形尺寸 Dimensions

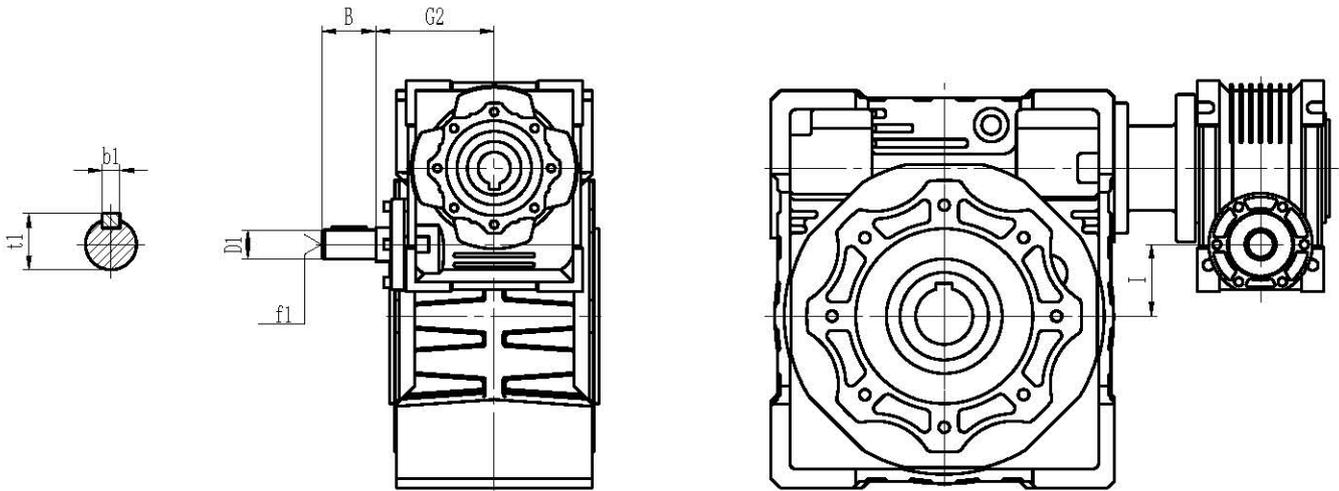

NRV-NMRV	030-040	030-050	030-063	040-075	040-090	050-110	063-130
B	20	20	20	23	23	30	40
D1	9 j6	9 j6	9 j6	11 j6	11 j6	14 j6	19 j6
G2	51	51	51	60	60	74	90
I	10	20	33	35	50	50	67
b1	3	3	3	4	4	5	6
f1	-	-	-	-	-	M6	M6
t1	10.2	10.2	10.2	12.5	12.5	16	21.5

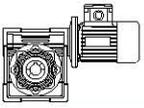

PAM B5外形尺寸 Dimensions

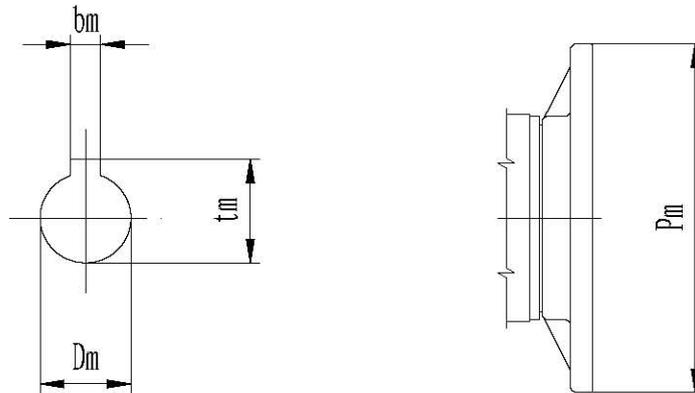

B5	IEC										
	056	063	071	080	090	100	112	132	160	180	200
Pm	120	140	160	200	200	250	250	300	350	350	400
Dm	9	11	14	19	24	28	28	38	42	48	55
bm	3	4	5	6	8	8	8	10	12	14	16
tm	10.4	12.8	16.3	21.8	27.3	31.3	31.3	41.3	45.3	51.8	59.3

PAM B14外形尺寸 Dimensions

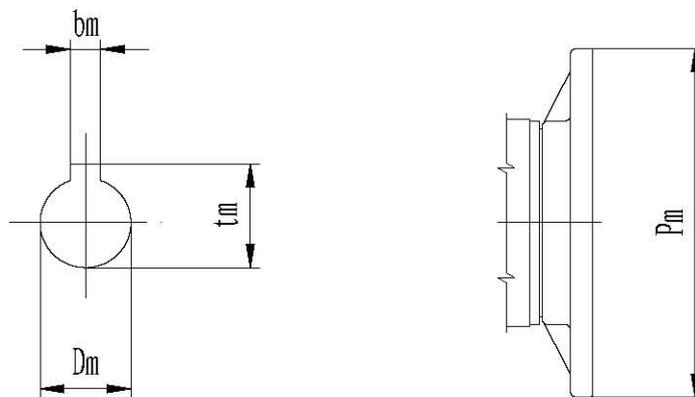

B14	IEC							
	056	063	071	080	090	110	112	132
Pm	80	90	105	120	140	160	160	200
Dm	9	11	14	19	24	28	28	38
bm	3	4	5	6	8	8	8	10
tm	10.4	12.8	16.3	21.8	27.3	31.3	31.3	41.3

UDL系列行星锥盘无级变速器

UDL Series planetary cone & disk step-less speed variator

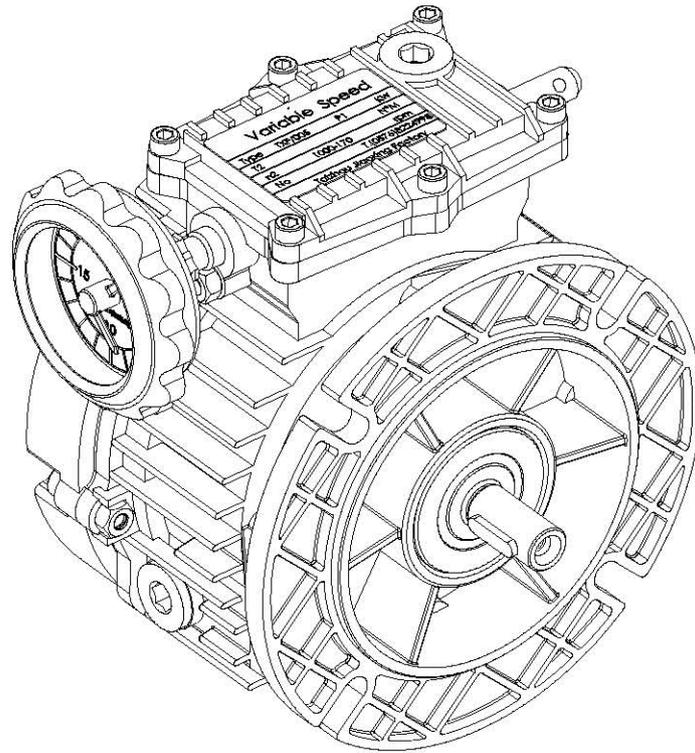

结构分解图 Structural breakdown drawing

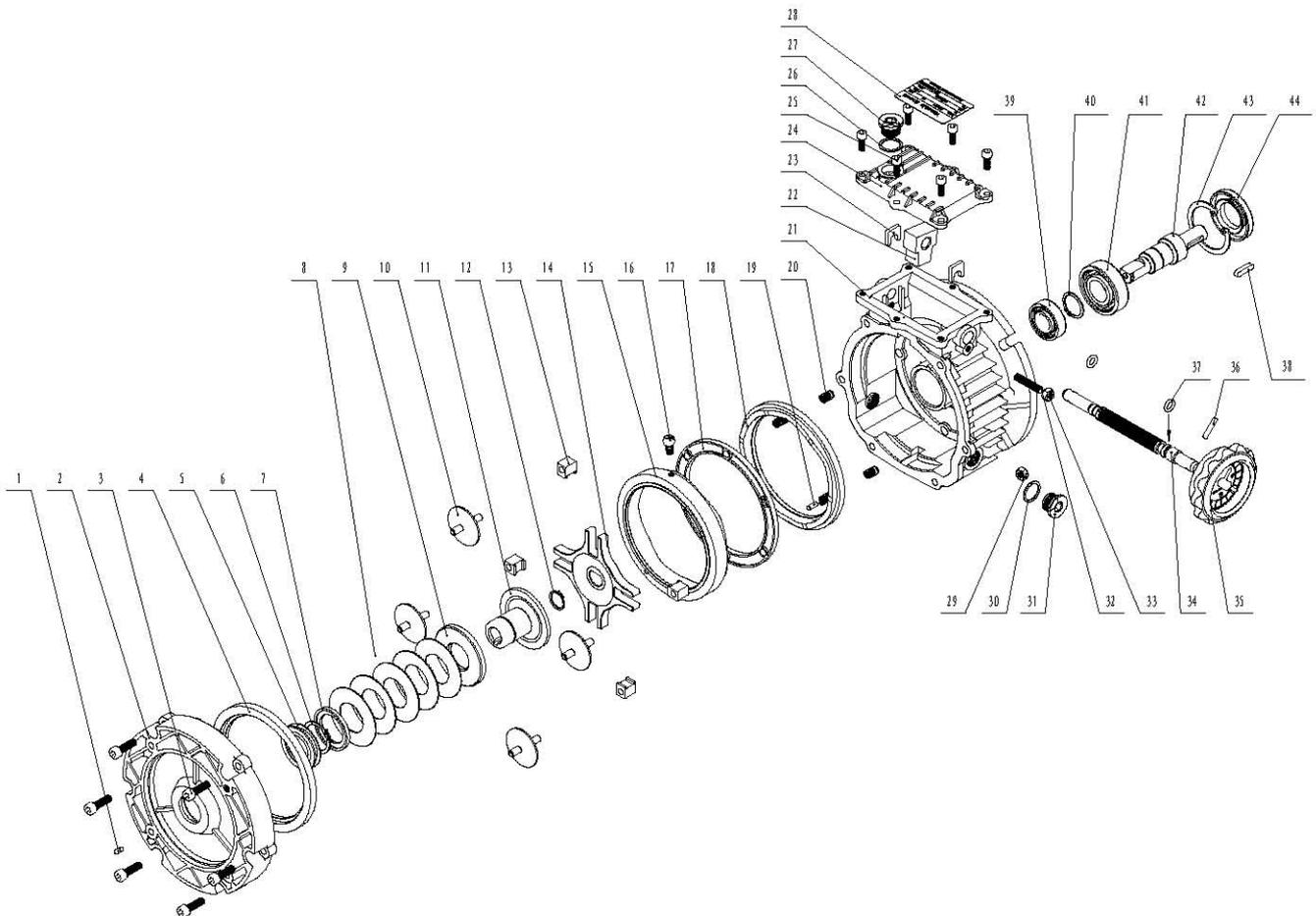

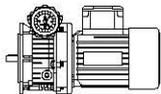

UDL型号标记 Model & marker

UDL 0.37 - B3



UDL特性表 Performance

n1	电机功率	机座号	n2 max	n2 min	M2 min	M2 max	滑差率 %	温升 °C
1400	0.18KW/4P	UDL002	880	170	1.5	3	3-3.8	46
	0.25KW/4P	UDL005	1000	170	2	6	3-8.8	46
	0.37KW/4P	UDL005	1000	170	3	6	3-8.8	46
	0.55KW/4P	UDL010	1000	170	4.4	12	3-8.8	46
	0.75KW/4P	UDL010	1000	170	6	12	3-8.8	46
	1.1KW/4P	UD020	950	165	9	18	3-8.8	46
	1.5KW/4P	UD020	950	165	12	24	3-8.8	46
	2.2KW/4P	UD030	1000	200	18	36	3-8.8	46
	3KW/4P	UD030/050	1000	200	24	48	3-8.8	46
	4KW/4P	UD050	1000	200	32	64	3-8.8	46
	5.5KW/4P	UD100	1000	200	45	90	3-8.8	50
	7.5KW/4P	UD100	1000	200	59	118	3-8.8	50

电机接口 Motor hicky

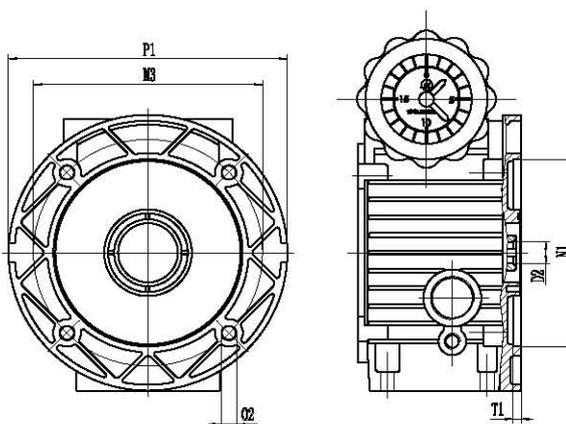

	PAM IEC	P1	N1(H8)	M3	O2	D2(F7)	T1
UDL0.18	63B5	140	95	115	M8	11	5
UDL0.25/0.37	71B5	160	110	130	M8	14	5
UDL0.55	80B5	200	130	165	M10	19	6
UDL0.75	90B5	200	130	165	M10	24	6
UD1.1/1.5	90B5	200	130	165	M10	24	6
UD2.2	100B5	250	180	215	M12	28	6
UD3.0/4.0	100/112B5						
UD5.5	132B5	300	230	265	M12	38	6
UD7.5							

可能的联接组合 Possible combination

*具体尺寸见UD系列样本
Detailed dimensions refer to UD series sample

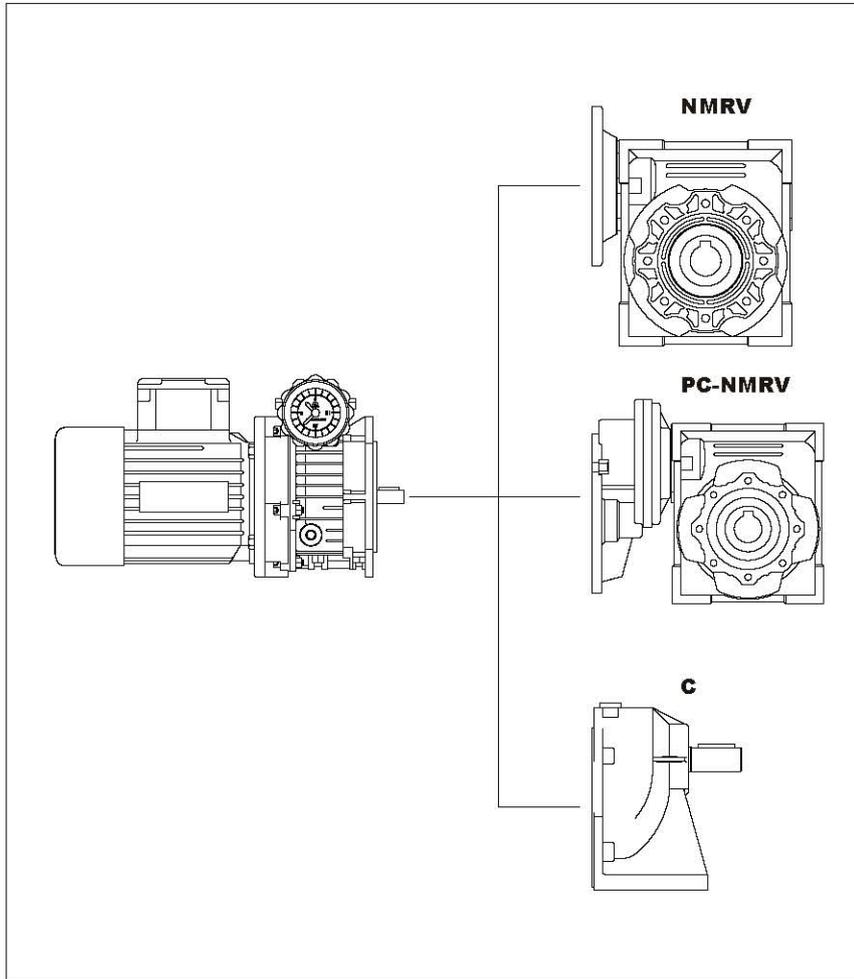

手轮位置图 Hand-wheel position diagram
默认配置为“1”位 Standard=POS. 1

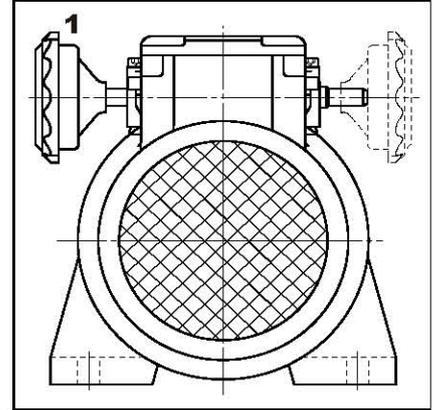

电机接线盒位置图
Motor terminal box position diagram

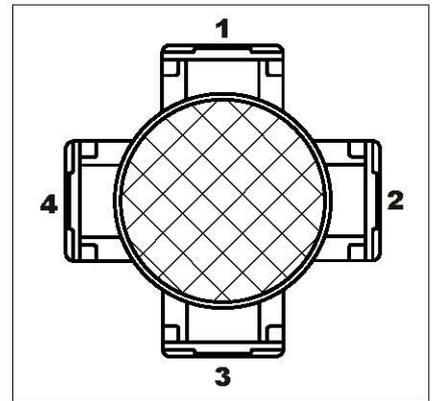

安装方位 Mounting

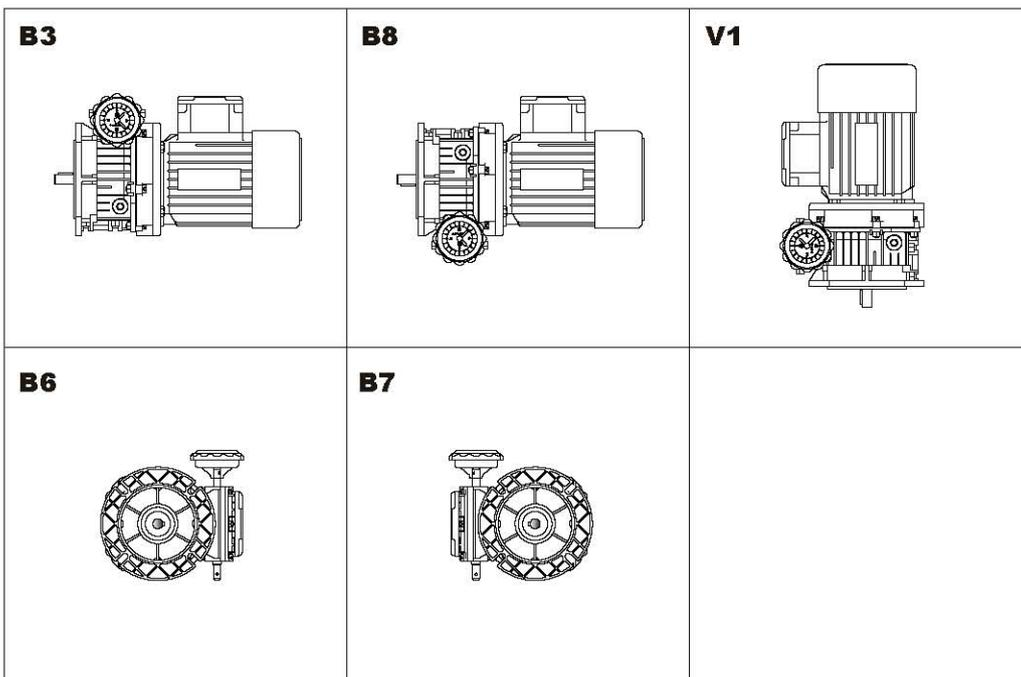

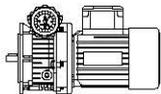

B3外形尺寸 Dimensions for B3 model

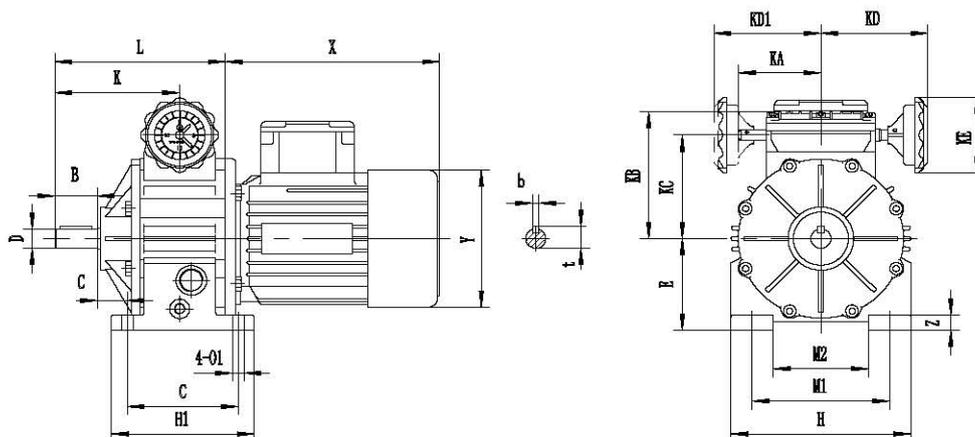

TYPE	B	D(j6)	C	C1	E	H	H1	K	L	M1	M2	O1	KA	KB	KC	KD	KD1	KE	b	t	X	Y	Z
UDL0.18B3	23	11	105	17.5	80	145	120	87.5	135.5	110	71	9	71	111	78	110	110	85	4	12.5	200	120	10
UDL0.25B3	30	14	104	20	93	149	125	104	140	120	96	9	71	123	90	110	110	85	5	16	227	141	10
UDL0.37B3	40	19	125	26	113	190	150	125.5	179	160	135	11	79	140	107	120	120	110	6	21.5	268	160	15
UD1.1B3	40	24	105	34.5	100	207	130	136	187	160	115	13	-	124	102	150	-	110	8	27	265	195	15
UD1.5B3	50	24	115	53.5	123	241	150	165	238	190	143	13	-	144	122	150	-	110	8	27	290	195	18
UD2.2B3	60	30	230	25	150	300	270	191	268	245	190	14	-	188	150	160	-	110	8	33	320	215	25
UD3.0B3	60	30	230	25	150	300	270	191	268	245	190	14	-	188	150	160	-	110	8	33	320	215	25
UD4.0B3	60	30	230	25	150	300	270	191	268	245	190	14	-	188	150	160	-	110	8	33	340	240	25
UD5.5B3	70	35	250	33	200	365	290	201	319	315	245	18	-	-	192	194	-	110	10	38	395	275	30
UD7.5B3	70	35	250	33	200	365	290	201	319	315	245	18	-	-	192	194	-	110	10	38	435	275	30

B5外形尺寸 Dimensions for B5 model

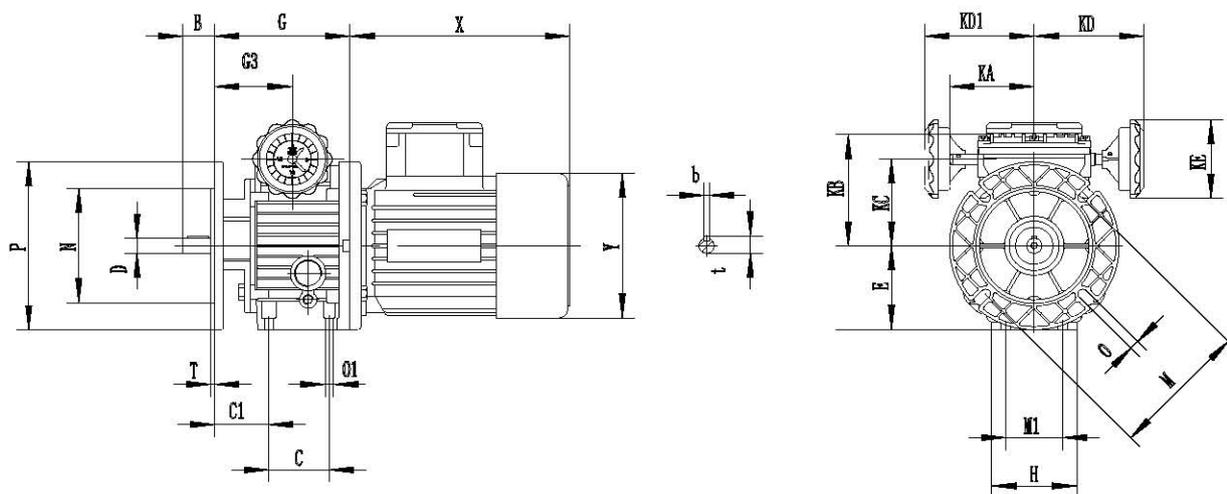

TYPE	B	D(j6)	C	G	G3	E	H	M	M1	N	O	O1	P	T	C1	KA	KB	KC	KD	KD1	KE	b	t	X	Y	Z
UDL0.18B5	23	11	50	112.5	64.5	70	72	115	60	95	9	M6	140	3.5	46	71	111	78	110	110	85	4	12.5	200	120	10
UDL0.25B5	30	14	40	110	74	80	90	130	77	110	9	M8	160	3.5	53	71	123	90	110	110	85	5	16	227	141	10
UDL0.37B5	40	19	58	139	85.5	100	98	165	84	130	11	M8	200	3.5	60	79	140	107	120	120	110	6	21.5	268	160	15
UD1.1B5	40	24	-	147	95	98	207	165	-	130	11	-	200	3.5	-	-	124	102	150	-	110	8	27	265	195	15
UD1.5B5	50	24	-	188	115	126	241	165	-	130	11	-	200	3.5	-	-	144	122	150	-	110	8	27	290	195	18
UD2.2B5	60	30	-	208	131	150	270	265	-	230	15	-	300	4	-	-	188	150	160	-	110	8	33	320	215	25
UD3.0B5	60	30	-	208	131	150	270	265	-	230	15	-	300	4	-	-	188	150	160	-	110	8	33	320	215	25
UD4.0B5	60	30	-	208	131	150	270	265	-	230	15	-	300	4	-	-	188	150	160	-	110	8	33	340	240	25
UD5.5B5	70	35	-	244	131	200	-	300	-	250	19	-	350	5	-	-	-	192	194	-	110	10	38	395	275	30
UD7.5B5	70	35	-	244	131	200	-	300	-	250	19	-	350	5	-	-	-	192	194	-	110	10	38	435	275	30